

Click to  
**ORDER**  
samples

## AMESP500U-277NZ

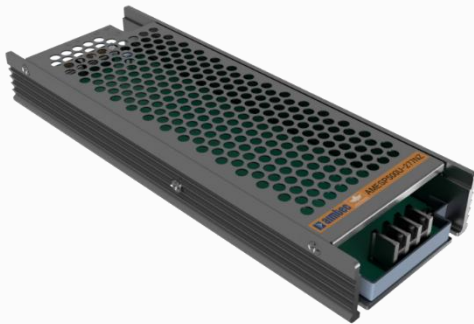

Enclosed

The AMESP500U-277NZ series is an efficient, enclosed, fan less, ultra-narrow, and semi-potted 500W AC/DC power supply module. It offers a wide commercial input voltage range of 90-305VAC, output voltage ranges from 4.2-55V, low power consumption, high efficiency, high reliability, and safer isolation.

This new series offers great operating temperatures, from -30°C to +70°C with full power up to 50°C and features an isolation of 3750VAC with improved reliability and system safety. Furthermore, a high MTBF of 256,400h, output short circuit protection (OSCP), output over-current protection (OCP), output over-voltage protection (OVP), and over temperature protection (OTP) come standard with the series.

The AMESP500U-277NZ is suitable for street lighting controls, grid power, instrumentation, industrial controls, communication, and civil applications.

## Features

- Universal Input: 90 - 305VAC/127 - 430VDC
- Operating Temp: -30°C to +70°C
- High isolation voltage: 3750VAC
- Active PFC
- Output short circuit, over-current, over-voltage, over-temperature protection
- Efficiency up to 94%
- DC OK active signal and redundant function (option)

## Summary

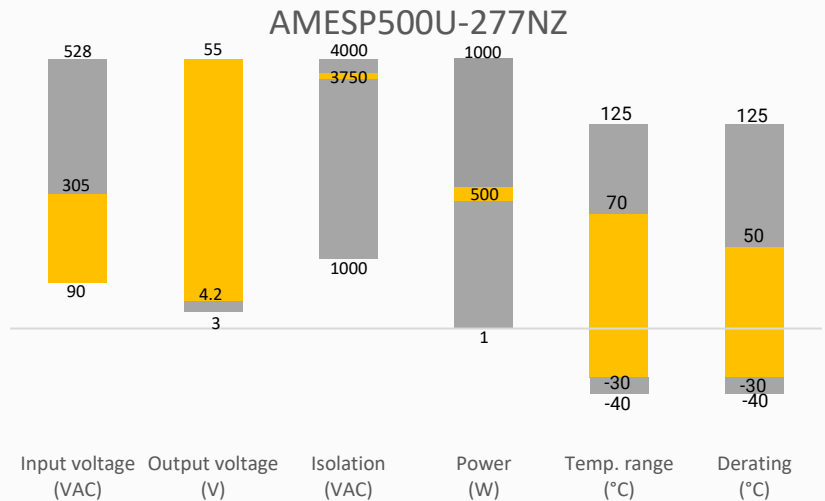

## Training



Product Training Video



Press Release

Coming Soon!

Application Notes

## Applications



Power Grid



Industrial



Telecom

## Models & Specifications



### Single Output

Model	Input Voltage (VAC/Hz)	Input Voltage (VDC)	Max Output Wattage (W)	Output Voltage (V)	Output Voltage Adjustable Range (V)	Output Current max (A)	Maximum capacitive load ( $\mu$ F)	Average Efficiency (%)
AMESP500U-4S277NZ-P	90-305/50-60	127-430	336	4.2	3.6-4.4	80	12000	89
AMESP500U-5S277NZ-P	90-305/50-60	127-430	400	5	4.5-5.5	80	12000	89
AMESP500U-12S277NZ-P	90-305/50-60	127-430	500.4	12	11.4-12.6	41.7	10000	93
AMESP500U-15S277NZ-P	90-305/50-60	127-430	501	15	14.3-15.8	33.4	9000	93
AMESP500U-24S277NZ-P	90-305/50-60	127-430	501.6	24	22.8-25.2	20.9	8000	93
AMESP500U-36S277NZ-P	90-305/50-60	127-430	500.4	36	34.2-37.8	13.9	6000	92
AMESP500U-48S277NZ-P	90-305/50-60	127-430	501.6	48	45.6-50.4	10.45	4000	94
AMESP500U-55S277NZ-P	90-305/50-60	127-430	500.5	55	45-58	9.1	2000	93

Note: The “-P” suffix indicates a terminal protective cover and conformal coating (ex. AMESP500U-12S277NZ-P). For optional built-in DC ok active signal and redundant function, add “R” after the “-P” (ex. AMESP500U-12S277NZ-PR is the built in DC ok signal and redundant function version with terminal protective cover and conformal coating).

### Input Specifications

Parameters	Conditions	Typical	Maximum	Units
Input current	115VAC	4.85		A
	230VAC	2.6		A
Inrush current	115VAC, cold start	30		A
	230VAC, cold start	60		A
Power factor	115VAC, Full load	0.98		
	230VAC, Full load	0.95		
Leakage current	240VAC		0.75	mA

### Output Specifications

Parameters	Conditions	Typical	Maximum	Units
Voltage accuracy	Full Load Range, 4.2V / 5V output	$\pm 2$		%
	Full Load Range, others	$\pm 1$		%
Line regulation	Rated Load, 4.2V / 5V output	$\pm 0.5$		%
	Rated Load, others	$\pm 0.3$		%
Load Regulation	0%-100% Load, 4.2V / 5V output	$\pm 1$		%
	0%-100% Load, others	$\pm 0.5$		%
Ripple & Noise*	4.2V, 5V, 12V, 15V output		200	mV p-p
	24V output		240	mV p-p
	36V, 48V output		360	mV p-p
	55V output		500	mV p-p
Hold up time	Full Load, 115VAC/230VAC	12		ms

\* Ripple and Noise are measured at 20MHz bandwidth with a 47 $\mu$ F electrolytic capacitor and a 0.1 $\mu$ F ceramic capacitor. Please refer to the application note for specific details.

### Isolation Specifications

Parameters	Conditions	Typical	Rated	Units
Tested I/O voltage	60 sec		3750	VAC
Tested Input to GND voltage	60 sec		2000	VAC
Tested Output to GND voltage	60 sec		1250	VAC
Resistance (I/O, I/O to GND) *	500VDC		100	M $\Omega$

\* Tested under 25±5°C ambient temperature with relative humidity <95% and no condensation.

### General Specifications

Parameters	Conditions	Typical	Maximum	Units
Safety class	Class I			
Over voltage category	OVC III / According to EN62368-1; altitude up to 2000 meters			
Over Current protection	Hiccup, Auto recovery	≥ 110	140	% of Iout
Over voltage protection	Shut-down, Manual recovery	≥ 115	135	% of Vout
Over temperature protection	Shut down o/p voltage, recovers automatically after temperature goes down.			
Short circuit protection	Hiccup, Auto recovery			
Operating temperature	See derating graph	-30 to +70		°C
Storage temperature		-40 to +85		°C
Power derating	40°C to 70°C, Conduction, 4.2V, 5V	1.67		% / °C
	45°C to 70°C, Conduction, 12V, 15V	2		% / °C
	50°C to 70°C, Conduction, others	2.5		% / °C
	40°C to 70°C, Convection, 110VAC, 4.2V, 5V	1		% / °C
	50°C to 70°C, Convection, 110VAC, 55V	1.5		% / °C
	40°C to 70°C, Convection, 110VAC, others	1.5		% / °C
	40°C to 70°C, Convection, 230VAC, 4.2V, 5V	1.33		% / °C
	40°C to 70°C, Convection, 230VAC, 12V, 15V	1.33		% / °C
	45°C to 70°C, Convection, 230VAC, 55V	2.4		% / °C
	45°C to 70°C, Convection, 230VAC, others	1.6		% / °C
Temperature coefficient	90VAC ~ 110VAC@60Hz	1		% / VAC
Temperature coefficient	0 ~ 50 °C	±0.03		% / °C
Cooling	Free air convection			
Humidity	Non-condensing, Storage	≥ 10	95	% RH
	Non-condensing, Operating	≥ 20	95	% RH
Case material	Metal			
Weight		905		g
Dimensions (L x W x H)	9.17 x 3.19 x 1.22inch (233 x 81 x 31mm)			
Vibration	10 ~ 500Hz, 5G 10min / 1cycle, 60min. Each along X, Y, Z axes			
MTBF	> 256 400 hrs MIL-HDBK-217(25°C)			

NOTE: All specifications in this datasheet are measured at an ambient temperature of 25°C, humidity<75%, nominal input voltage and at rated output load unless otherwise specified.

### Safety Specifications

Parameters		
Standards	Over voltage category	Design to meet III; According to EN62368-1
	Information technology Equipment	Design to meet EN62368-1, UL62368-1, BS EN62368-1, EN60335-1, EN61558-1
	EMC - Conducted and radiated emission	CISPR32 / EN55032, class B
	Harmonic current	IEC 61000-3-2
	Voltage flicker	IEC 61000-3-3
	Electrostatic Discharge Immunity	IEC 61000-4-2
	RF, Electromagnetic Field Immunity	IEC 61000-4-3
	Electrical Fast Transient/Burst Immunity	IEC 61000-4-4
	Surge Immunity	IEC 61000-4-5
	RF, Conducted Disturbance Immunity	IEC 61000-4-6
	Power-frequency Magnetic Field	IEC 61000-4-8
Voltage dips, Short Interruptions Immunity	IEC 61000-4-11	

Derating

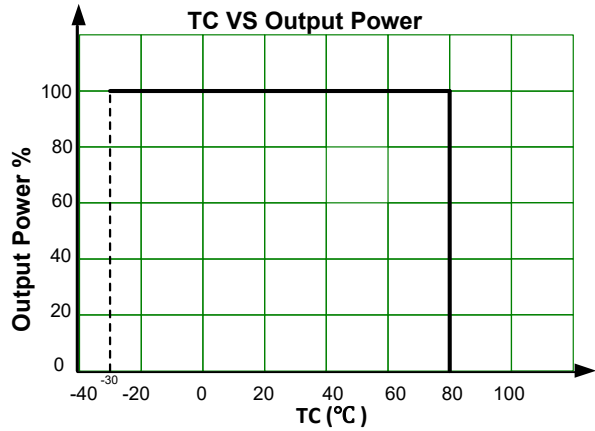
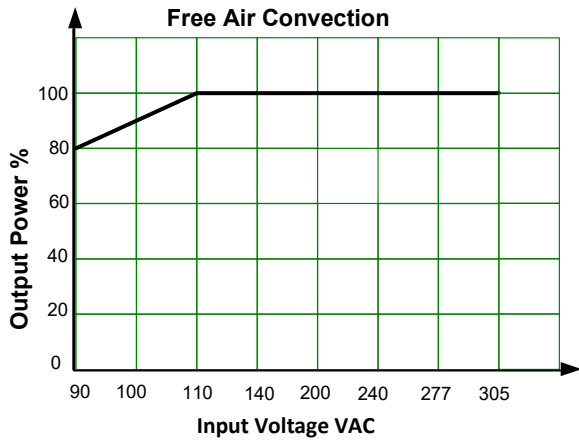
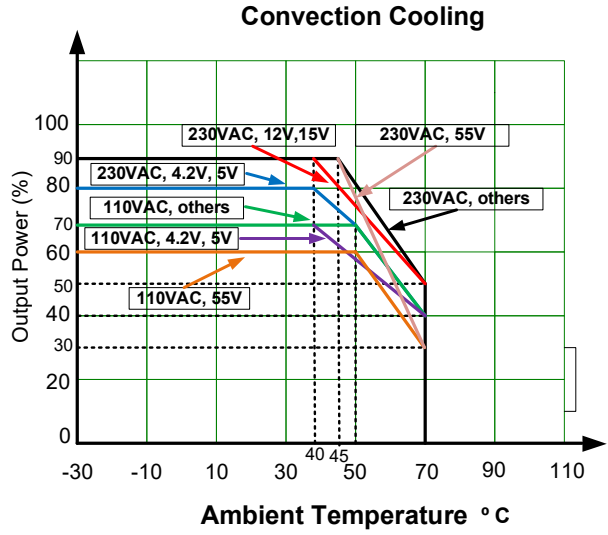
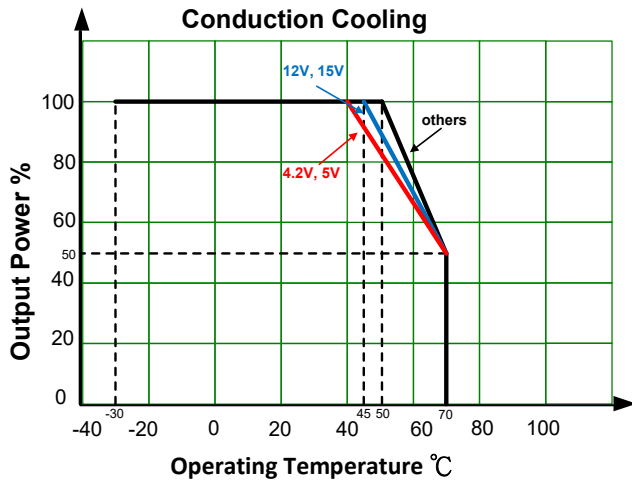

Please refer to Dimension for the TC position.

## Dimensions

Pin Output Specifications	
Pin	Single
1	PE GND
2	AC Input (N)
3	AC Input (L)
4	+V Output
5	+V Output
6	-V Output
7	-V Output



CN1 (DC OK connector) DL20001-AWD or equivalent	
Pin	Single
1	-V <sub>DC OK</sub>
2	+V <sub>DC OK</sub>

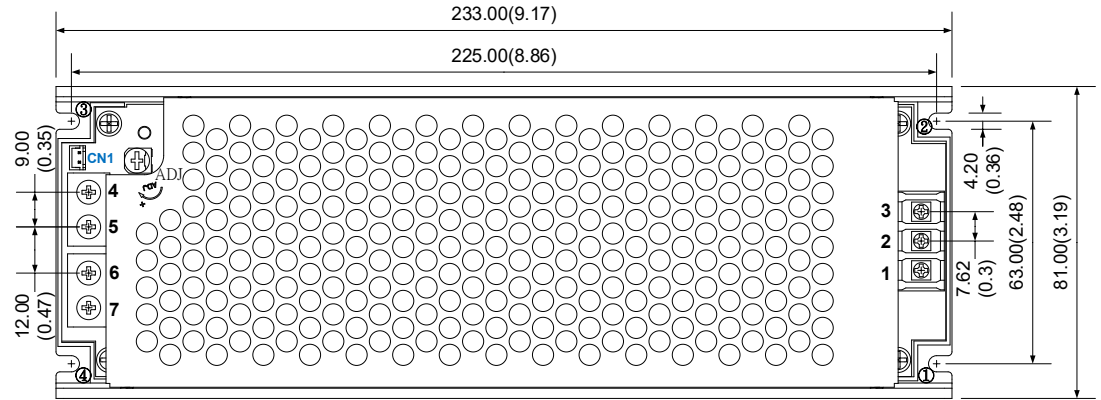

Note:  
Unit: mm(inch)  
General tolerance:  $\pm 1.0(0.04)$

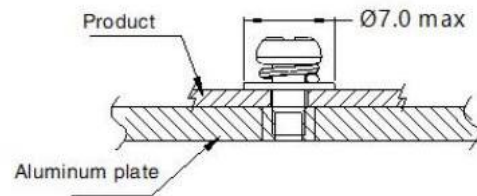
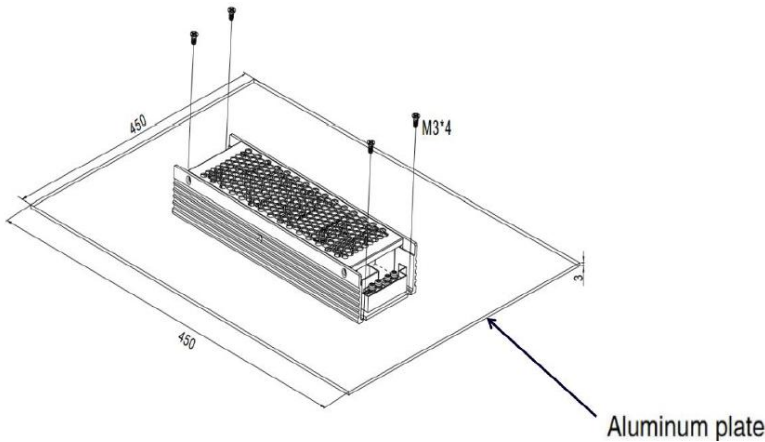

Position	Screw Spec.	Torque(max)
① - ④	M3	0.4N · m

Note:

- Operate with additional aluminum plate to meet the "Derating Curve" and the "Static Characteristics", the series model must be installed onto an aluminum plate (or the cabinet of the same size) on the bottom. The size of the suggested aluminum plate is 450mm x 450mm. And for optimizing thermal performance, the aluminum plate must have an even and smooth surface (or coated with thermal grease), and the series model must be firmly mounted at the center of the aluminum plate.
- It is suggested to install the product with M3 combination screws, and the product must be firmly installed at the center of the aluminum plate.

## Block Diagram

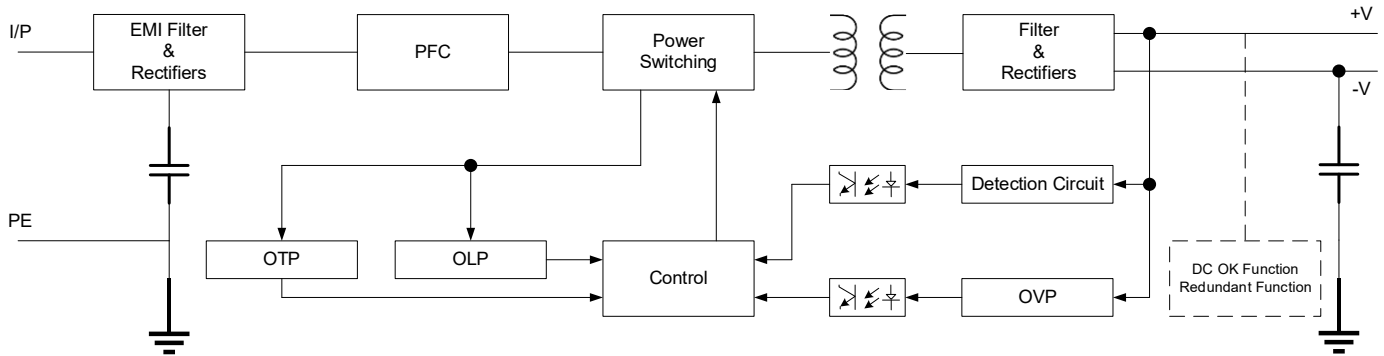

## Function

DC OK Signal (Option)	Contact rating (max.): 30VDC/1A resistive load
Redundant (Option)	For parallel applications, if one power supply unit (PSU) fails, the other will automatically take over. This ensures continuous operation, prevents system crashes, and enhances overall system reliability.

## Function Manual

### 1. DC OK Relay Contact

Contact Close	PSU turns on	DC OK
Contact Open	PSU turns off	DC Fail
Contact Rating (Max.)	30VDC/1A resistive load	

### 2. Redundant Function

- AMESP500U-XXS277NZ-PR features a built-in redundancy function and supports parallel connection of two units.
- During parallel operation, the total load should not exceed the rated power of a single power supply unit (PSU).

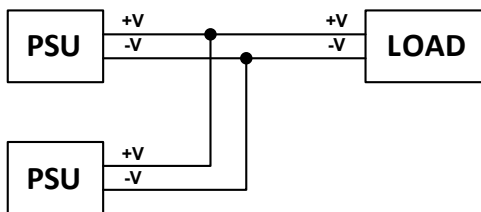

**NOTE:** 1. Datasheets are updated as needed and as such, specifications are subject to change without notice. Once printed or downloaded, datasheets are no longer controlled by Aimtec; refer to [www.aimtec.com](http://www.aimtec.com) for the most current product specifications. 2. Product labels shown, including safety agency certifications on labels, may vary based on the date manufactured. 3. Mechanical drawings and specifications are for reference only. 4. All specifications are measured at an ambient temperature of 25°C, humidity<75%, nominal input voltage and at rated output load unless otherwise specified. 5. Aimtec may not have conducted destructive testing or chemical analysis on all internal components and chemicals at the time of publishing this document. CAS numbers and other limited information are considered proprietary and may not be available for release. 6. This product is not designed for use in critical life support systems, equipment used in hazardous environments, nuclear control systems or other such applications which necessitate specific safety and regulatory standards other the ones listed in this datasheet. 7. Warranty is in accordance with Aimtec's standard Terms of Sale available at [www.aimtec.com](http://www.aimtec.com).