

Click to
ORDER
samples

AMESP320-277NZ



Enclosed

The AMESP320-277NZ is Aimtec's highest power AC/DC converter that offers much greater cost effectiveness due to material normalization and production automation also leading to improved reliability and performance. Offering a commercial input voltage range of 90-305VAC and an output voltage range from 5-48V, this series will offer many benefits to your new system design.

This new series offers great operating temperatures, from -30°C to 50°C with full power and also features an isolation of 3000VAC for improved reliability and system safety. Furthermore, a high MTBF of 180,000h, output short circuit protection (OSCP), output over-current protection (OCP), output over-voltage protection (OVP) and over-temperature protection (OTP) come standard with the series.

The AMESP320-277NZ is suitable for street lighting controls, grid power, instrumentation, industrial controls, communication, and civil applications.

Features



- Universal Input: 90 - 305VAC/127 - 430VDC
- Operating Temp: -30 °C to +70 °C
- PFC>0.95
- High isolation voltage: Up to 3000VAC
- Low ripple & noise, 240mV(p-p) typ.
- Output short circuit, over-current, over-voltage and over temperature protection
- Regulated Output
- Active power factor correction

Summary

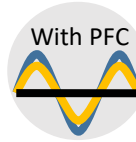
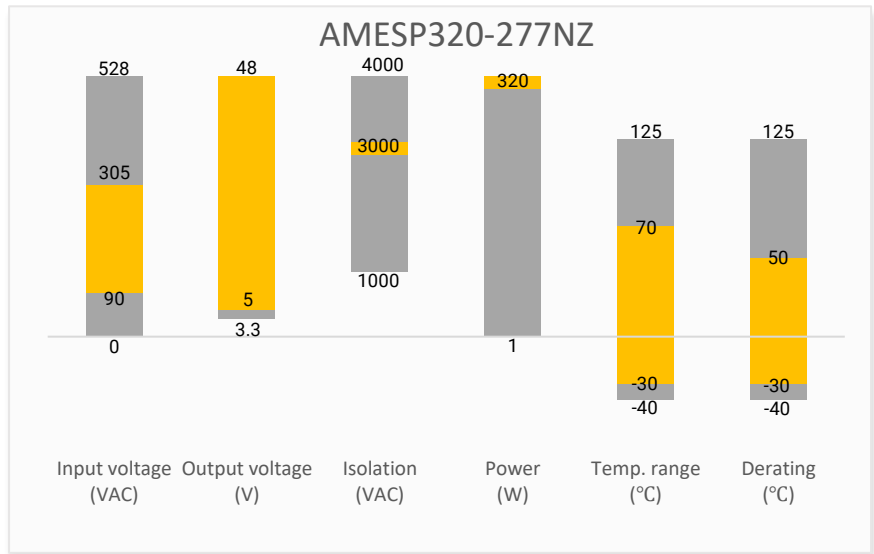

Training



Product Training Video
(click to open)

 Press Release

 Coming Soon!

Application Notes

Applications



Power Grid



Industrial



Telecom



Instrumentation

Models & Specifications

Single Output								
Model	Input Voltage (VAC/Hz)	Input Voltage (VDC)	Max Output Wattle (W)	Output Voltage (V)	Output Voltage Adjustable Range (V)	Output Current max (A)	Maximum capacitive load (μ F)	Average Efficiency (%)
AMESP320-5S277NZ-P	90-305/47-63	127-430	300	5	4.5-5.5	60	4000	83
AMESP320-12S277NZ-P	90-305/47-63	127-430	320.4	12	10.0-13.2	26.7	3300	88
AMESP320-15S277NZ-P	90-305/47-63	127-430	321	15	13.5-18.0	21.4	1500	88.5
AMESP320-24S277NZ-P	90-305/47-63	127-430	321.6	24	20.0-26.4	13.4	1000	89
AMESP320-36S277NZ-P	90-305/47-63	127-430	320.4	36	32.4-39.6	8.9	700	89.5
AMESP320-48S277NZ-P	90-305/47-63	127-430	319.7	48	43.2-52.8	6.66	470	90

Note: The "-P" suffix indicates a terminal protective cover and conformal coating (ex. AMESP320-5S277NZ-P).

Input Specifications				
Parameters	Conditions	Typical	Maximum	Units
Input current	115VAC	4		A
	230VAC	2		A
Inrush current	115VAC, cold start	20		A
	230VAC, cold start	40		A
Power factor	115VAC, Full load	0.98		
	230VAC, Full load	0.95		
Leakage current	240VAC		1	mA

Output Specifications				
Parameters	Conditions	Typical	Maximum	Units
Voltage accuracy	Full load	± 2		%
Line regulation	Full load	± 0.5		%
Load regulation	0-100% load, 5V, 12V, 15V output	± 1		%
	0-100% load, 24V, 36V, 48V output	± 0.5		%
Ripple & Noise*	36V output		180	mV p-p
	48V output		240	mV p-p
	Others		150	mV p-p
Hold up time	115&230VAC	8		ms

* Ripple and Noise are measured at 20MHz bandwidth with a 47 μ F electrolytic capacitor and a 0.1 μ F ceramic capacitor. Please refer to the application note for specific details.

Isolation Specifications				
Parameters	Conditions	Typical	Rated	Units
Tested I/O voltage	60 sec		3000	VAC
Tested Input to GND voltage	60 sec		2000	VAC
Tested Output to GND voltage	60 sec		500	VAC
Resistance (I/O, I/O to GND) *	500VDC		100	M Ω

* Tested under 25 \pm 5 $^{\circ}$ C ambient temperature with relative humidity <95% and no condensation.

General Specifications				
Parameters	Conditions	Typical	Maximum	Units
Safety class	Class I			
Over voltage category	OVC III			
Over Current protection	Hiccup, Auto recovery	≥ 105	135	% of Iout
Over voltage protection	Shut-down, Manual recovery, 5V output		6.75	VDC
	Shut-down, Manual recovery, 12V output		16.2	VDC
	Shut-down, Manual recovery, 15V output		20.25	VDC
	Shut-down, Manual recovery, 24V output		32.4	VDC
	Shut-down, Manual recovery, 36V output		48.6	VDC
	Shut-down, Manual recovery, 48V output		68	VDC
Over temperature protection	Shut-down, Auto recovery			
Short circuit protection	Hiccup, Continuous, Auto recovery			
Operating temperature	See derating graph	-30 to +70		°C
Storage temperature		-40 to +85		°C
Power derating	50 °C to 70 °C	2.5		% / °C
	90VAC ~ 105VAC@60Hz	1.67		% / VAC
Temperature coefficient		±0.03		% / °C
Cooling	Forced air cooling			
Humidity	Non-condensing, Storage	≥ 10	95	% RH
	Non-condensing, Operating	≥ 20	90	% RH
Case material	Metal			
Weight		1000		g
Dimensions (L x W x H)	8.46 x 4.53 x 1.18inch (215.0 x 115.0 x 30.0mm)			
Vibration	10 ~ 500H, 2G 10min / 1cycle, 60min. Each along X, Y, Z axes			
MTBF	> 180 000 hrs MIL-HDBK-217(25°C)			
NOTE: All specifications in this datasheet are measured at an ambient temperature of 25°C, humidity<75%, nominal input voltage and at rated output load unless otherwise specified.				

Safety Specifications		
Parameters		
Standards	Over voltage category	Design to meet III; According to EN62368-1
	Information technology Equipment	Design to meet BS EN/EN62368-1, BS EN/EN61558-1
	EMC - Conducted and radiated emission	CISPR32 / EN55032, class B
	Harmonic current	IEC 61000-3-2
	Voltage flicker	IEC 61000-3-3
	Electrostatic Discharge Immunity	IEC 61000-4-2
	RF, Electromagnetic Field Immunity	IEC 61000-4-3
	Electrical Fast Transient/Burst Immunity	IEC 61000-4-4
	Surge Immunity	IEC 61000-4-5
	RF, Conducted Disturbance Immunity	IEC 61000-4-6
Power frequency magnetic field immunity	IEC 61000-4-8	

Derating

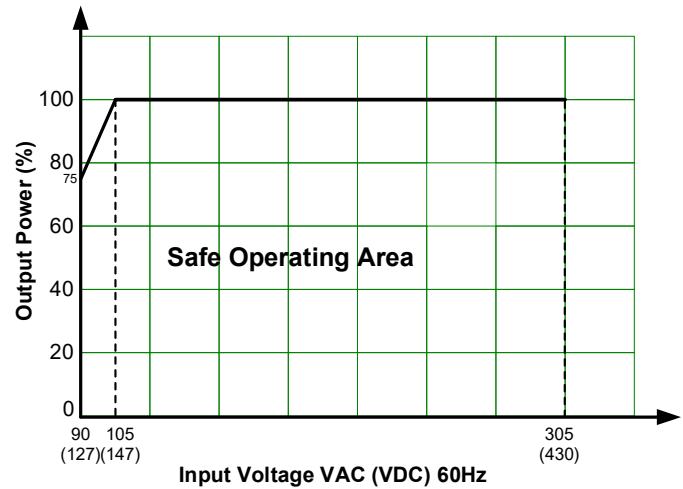
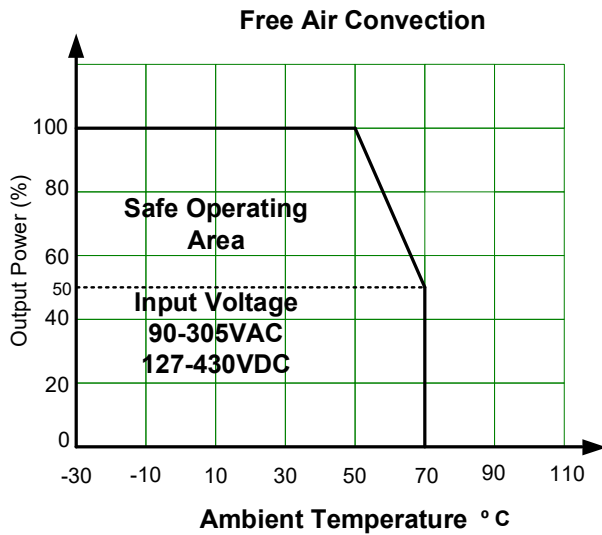

Functional Diagram

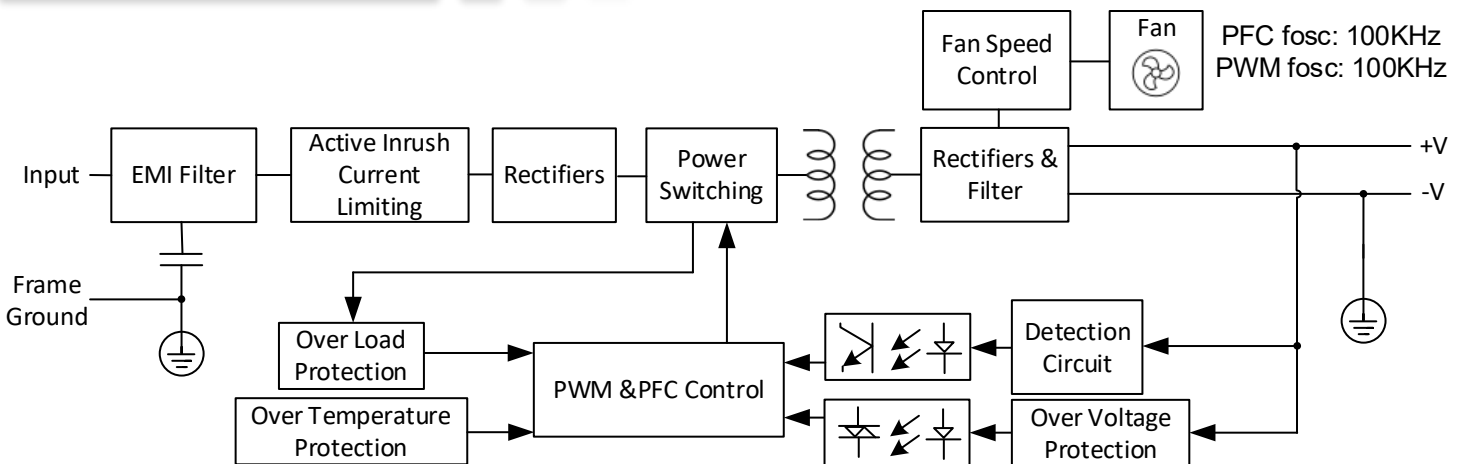

Dimensions

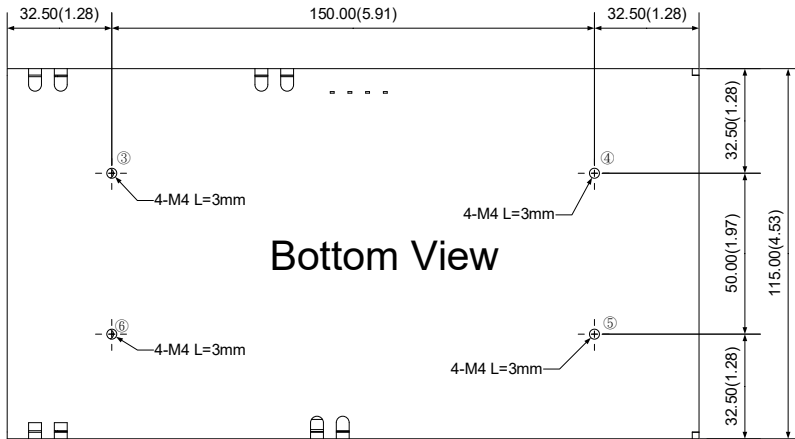

Pin Output Specifications	
Pin	Single
1	+V Output
2	+V Output
3	+V Output
4	-V Output
5	-V Output
6	-V Output
7	GND
8	AC Input (N)
9	AC Input (L)

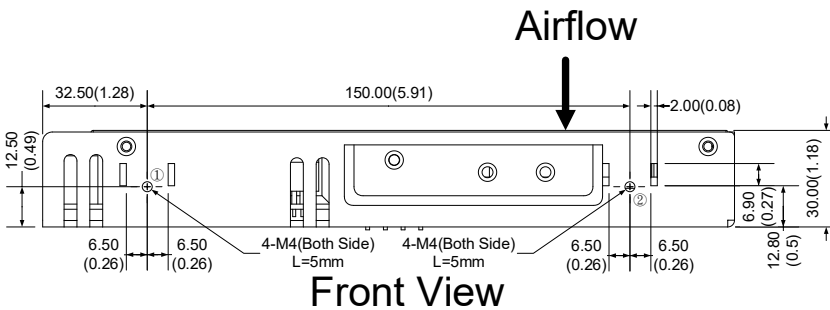

Note:
Unit: mm(inch)
Connector screw: M3.5

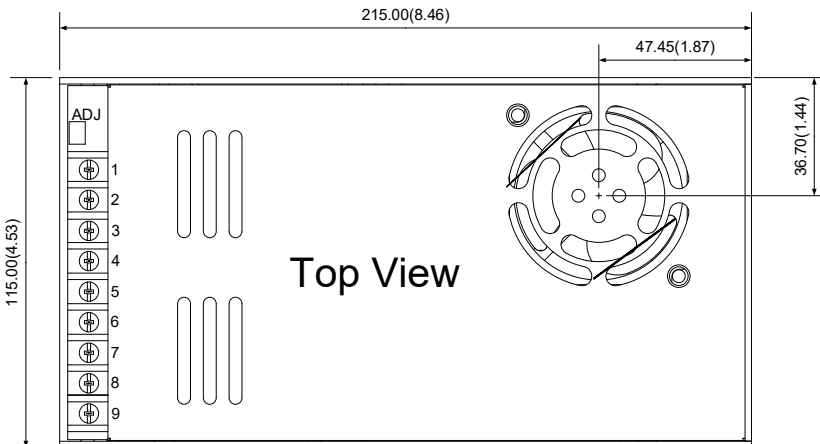

NOTE: 1. Datasheets are updated as needed and as such, specifications are subject to change without notice. Once printed or downloaded, datasheets are no longer controlled by Aimtec; refer to www.aimtec.com for the most current product specifications. 2. Product labels shown, including safety agency certifications on labels, may vary based on the date manufactured. 3. Mechanical drawings and specifications are for reference only. 4. All specifications are measured at an ambient temperature of 25°C, humidity<75%, nominal input voltage and at rated output load unless otherwise specified. 5. Aimtec may not have conducted destructive testing or chemical analysis on all internal components and chemicals at the time of publishing this document. CAS numbers and other limited information are considered proprietary and may not be available for release. 6. This product is not designed for use in critical life support systems, equipment used in hazardous environments, nuclear control systems or other such applications which necessitate specific safety and regulatory standards other the ones listed in this datasheet. 7. Warranty is in accordance with Aimtec's standard Terms of Sale available at www.aimtec.com.