

Click to  
**ORDER**  
samples

**AMEOFL3-277HALPZ**

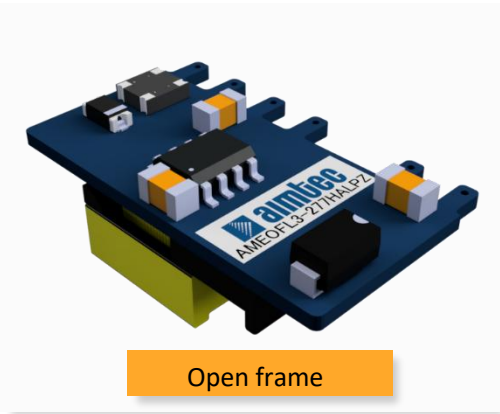

The AMEOFL3-277HALPZ series is one of Aimtec’s highly efficient, green 3W AC-DC converter series. It features an ultra-wide input range accepting either AC or DC voltage, high efficiency, compact size in an open-frame, low power consumption and CLASS II reinforced insulation. A variety of EMC external circuits enable this series to meet the needs of multiple industries.

This 3W converter offers great operating temperatures, from -40°C to 85°C and also boasts an isolation of 4000VAC for improved reliability and system safety. Furthermore, a high MTBF of 1,000,000h, output short circuit protection (OSCP) and an output over-current protection (OCP) come standard with the series.

All models are suitable for industrial control, electric power, instrumentation and smart home applications.

**Features**



- Universal Input: 85 - 305VAC/100 - 430VDC
- Operating Temp: -40 °C to +85 °C
- High isolation voltage: 4000VAC
- Low ripple & noise, 150mV(p-p), max.
- Output short circuit, over-current
- Open frame package
- Agency approvals: UL62368-1
- Designed to meet IEC/EN 62368-1, EN60335-1, EN61558-1

**Summary**

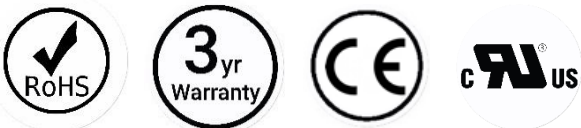
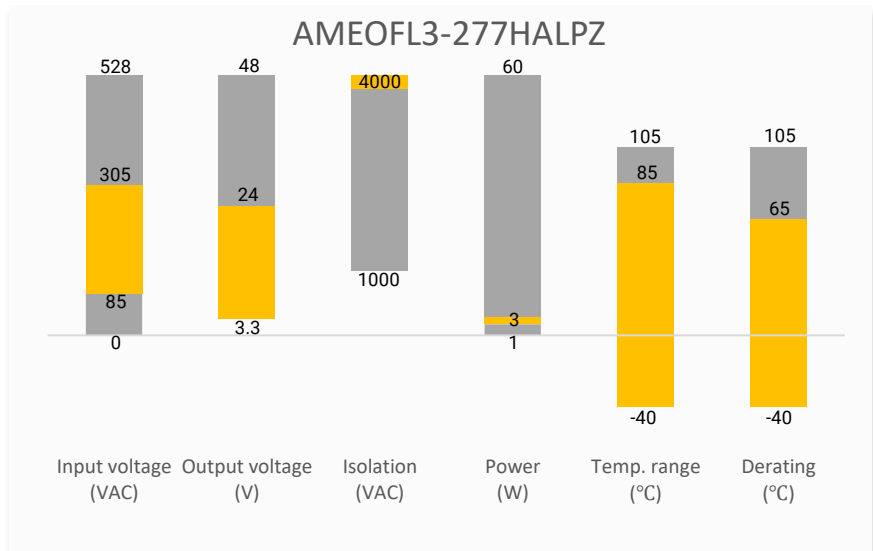

**Training**

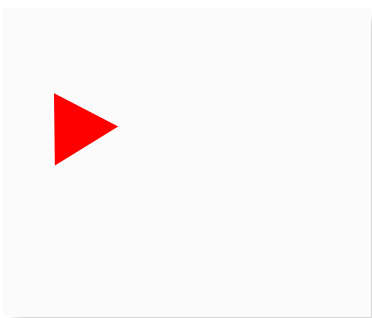

Product Training Video  
(click to open)

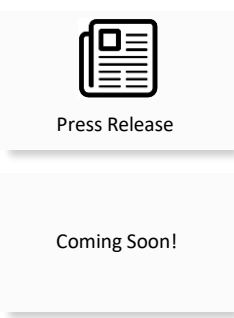

Application Notes

**Applications**



Power Grid



Industrial



Telecom



Instrumentation

## Models & Specifications

### Single Output

Model	Input Voltage (VAC/Hz)	Input Voltage (VDC)	Max Output wattage (W)	Output Voltage (V)	Output Current max (A)	Maximum capacitive load ( $\mu$ F)	Efficiency @ 230VAC (%)
AMEOFL3-3S277HALPZ	85~305/47~63	100~430	3	3.3	0.6	1500	68
AMEOFL3-5S277HALPZ	85~305/47~63	100~430	3	5	0.6	1500	73
AMEOFL3-9S277HALPZ	85~305/47~63	100~430	3	9	0.34	680	77
AMEOFL3-12S277HALPZ	85~305/47~63	100~430	3	12	0.25	470	77
AMEOFL3-15S277HALPZ	85~305/47~63	100~430	3	15	0.2	330	78
AMEOFL3-24S277HALPZ	85~305/47~63	100~430	3	24	0.125	100	81

### Input Specifications

Parameters	Conditions	Typical	Maximum	Units
Input Current	115VAC		150	mA
	230VAC		70	mA
Inrush current	115VAC	20		A
	230VAC	40		A
External fuse	Slow blow type	1		A
Input filter	External EMC filter (refer to recommended EMC circuit)			

### Output Specifications

Parameters	Conditions	Typical	Maximum	Units
Voltage accuracy	10% - 100% load	$\pm 5$		%
Line regulation	Full load, 3.3Vout	$\pm 2.5$		%
	Full load, others	$\pm 1.5$		%
Load regulation	10% - 100% load	$\pm 3$		%
Ripple & Noise	20MHz bandwidth, 10% - 100% load	80	150	mV p-p

NOTE: The output minimum load is 10%

\* Ripple and Noise are measured at 20MHz bandwidth with a 47 $\mu$ F electrolytic capacitor and a 0.1 $\mu$ F ceramic capacitor. Please refer to the application note for specific details.

### Isolation Specifications

Parameters	Conditions	Typical	Rated	Units
Tested I/O voltage	60 sec, 5mA max		4000	VAC
Insulation Resistance	500VDC	>100		M $\Omega$

General Specifications				
Parameters	Conditions	Typical	Maximum	Units
Switching frequency		65		Khz
Safety class	Class II			
Oversvoltage category	OVC II			
Over Current protection	Auto recovery	≥ 110		% of Iout
Short circuit protection	Hiccup, Continuous, Auto recovery			
Power consumption		0.1		W
Power derating	+65 °C to +85 °C	3.0		% / °C
Operating temperature		-40 to +85		°C
Storage temperature		-40 to +105		°C
Temperature coefficient		±0.15		% / °C
Cooling	Free air convection			
Storage Humidity			95	% RH
Weight		5		g
Dimensions (L x W x H)	1.04 x 0.58 x 0.43 inches (26.40 x 14.80 x 11.0 mm)			
MTBF	> 1 000 000 Hours (MIL-HDBK -217F, t=+25°C)/Full Load			

NOTE: All specifications in this datasheet are measured at an ambient temperature of 25°C, humidity<75%, nominal input voltage and at rated output load unless otherwise specified.

Safety Specifications	
Parameters	
Agency Approvals	UL 62368-1 Designed to meet IEC/EN 62368-1, EN 60335-1, EN 61558-1
Standards	EMC - Conducted and radiated emission CISPR32 / EN55032, class A CISPR32 / EN55032, class B (with the recommended EMC circuit)
	Electrostatic Discharge Immunity IEC/EN61000-4-2 Contact ±6KV, Air ±8KV, Criteria B
	RF, Electromagnetic Field Immunity IEC/EN61000-4-3 10V/m, Criteria A
	Electrical Fast Transient/Burst Immunity IEC/EN61000-4-4 ±2KV, Criteria B ±4KV, Criteria B (with the recommended EMC circuit)
	Surge Immunity IEC/EN61000-4-5 L-L ±1KV, Criteria B L-L ±2KV, Criteria B (with the recommended EMC circuit)
	RF, Conducted Disturbance Immunity IEC/EN61000-4-6 10Vr.m.s, Criteria A

## Derating

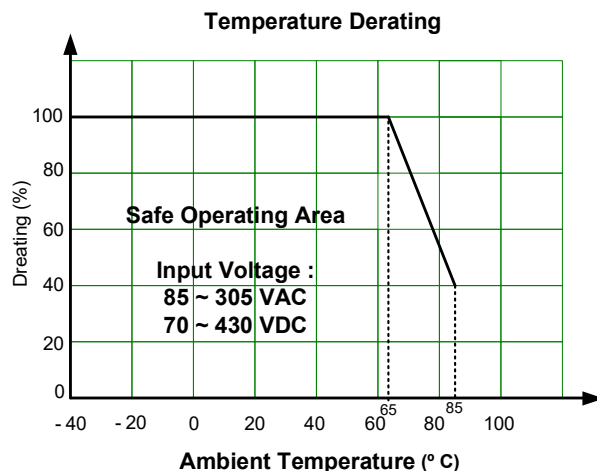

## Typical Application Circuit

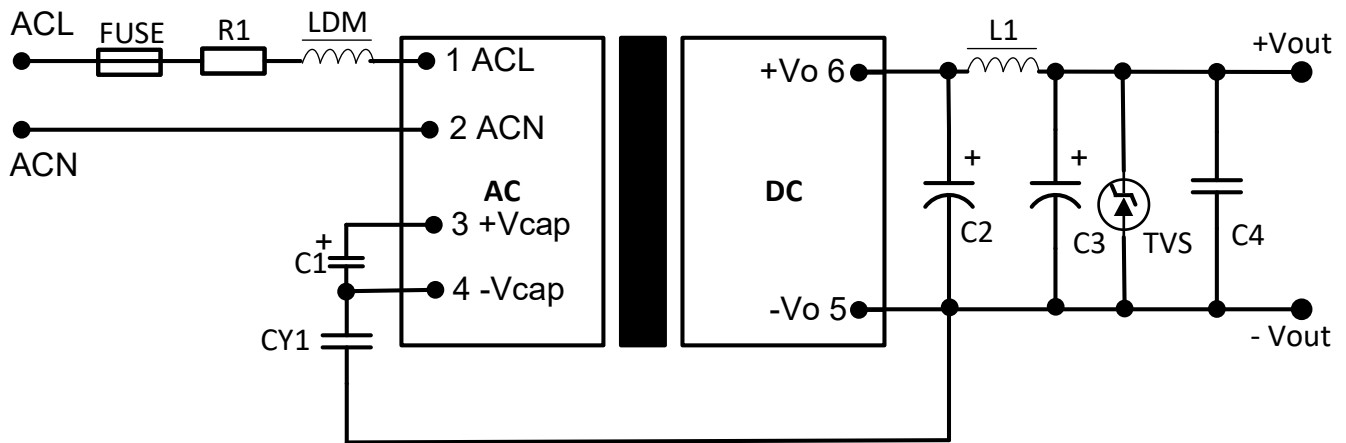

\*This circuit is the basic design reference, components with "\*" are required for the converter's operation.

\*FUSE\* to be 1A, slow blow and is also required for safety. R1\* is 12Ω, 3W, wire-wound resistor.

Vout	C1*	C2*	C3*	C4	CY1*	L1*	TVS
3.3V, 5V	10uF, 450VDC	560uF, 16V	100uF, 35V	0.1uF, 50V	1nF, 400VAC	2.2uH, 3A	SMBJ7.0A
9V, 12V	10uF, 450VDC	330uF, 25V	100uF, 35V	0.1uF, 50V	1nF, 400VAC	2.2uH, 3A	SMBJ12A
15V, 24V	10uF, 450VDC	330uF, 35V	47uF, 35V	0.1uF, 50V	1nF, 400VAC	3.3uH, 2A	SMBJ20A

## EMC Recommended Circuit

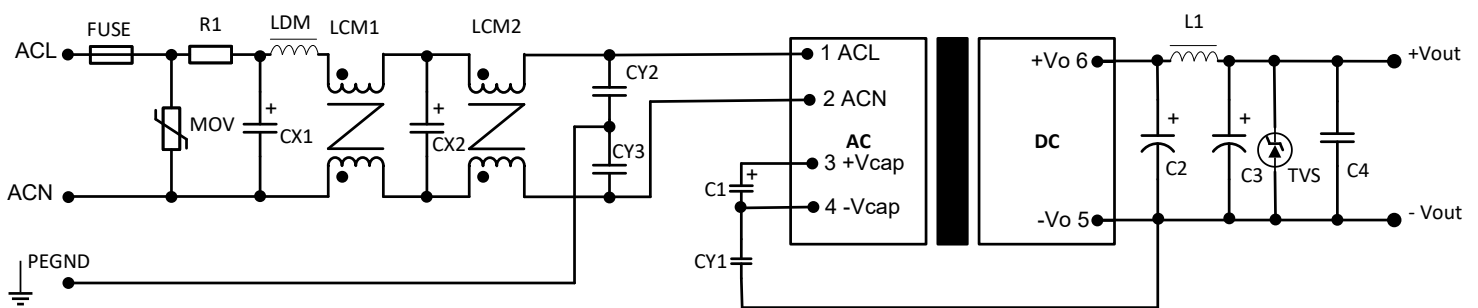

\*Components above with "\*" are required for the converter's operation. "R1" is wire-wound resistor. For other components, please refer to the typical application circuit

Component	FUSE*	R1*	MOV	LDM	LCM1	LCM2	CX1, CX2	CY1, CY2, CY3
Spec	2A, 300V	12Ω, 3W	14D561	2.2mH	200uH	12.6mH	0.1uF, 310VAC	1nF, 400VAC

## Dimensions

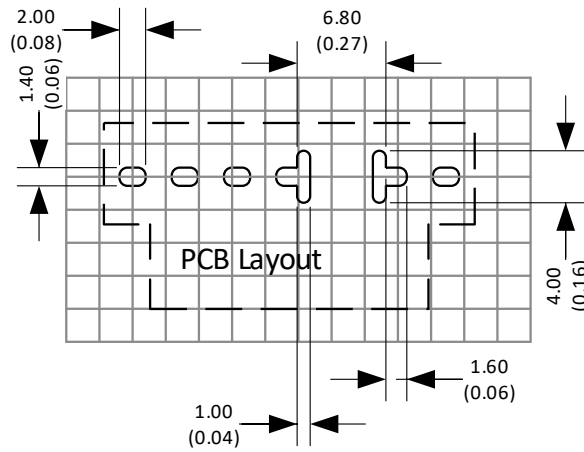
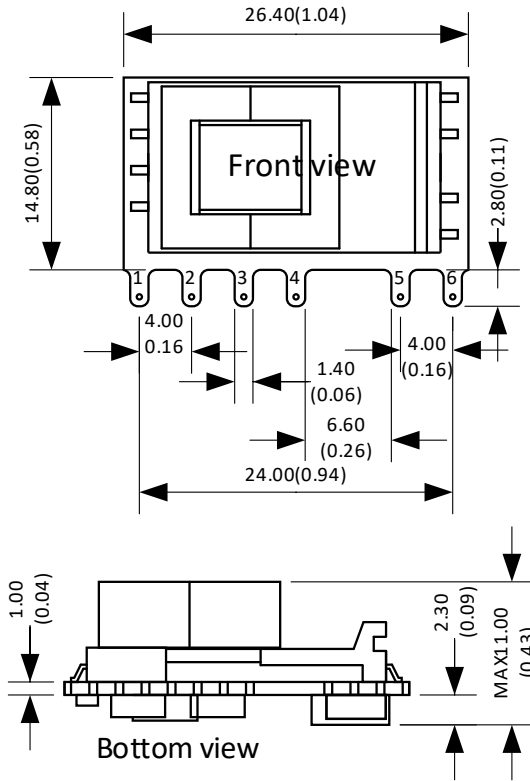

Unless otherwise specified unit: mm(inch)

General tolerance:  $\pm 1.00(\pm 0.04)$

Pin thickness:  $\pm 0.15(\pm 0.006)$

Footprint grid 2.54x2.54 mm

Pin Output Specifications

Pin	Function
1	+V Input (L)
2	-V Input (N)
3	+V_Cap
4	-V_Cap
5	-V Output
6	+V Output

1. It is necessary to add C1 between pin3 to pin4
2. It is necessary to add circuit to the output as shown in recommended circuit
3. The layout of the device is for reference only, please refer to the actual product
4. The slots between pin 4 and pin 5 are required for creepage distance consideration.

**NOTE:** 1. Datasheets are updated as needed and as such, specifications are subject to change without notice. Once printed or downloaded, datasheets are no longer controlled by Aimtec; refer to [www.aimtec.com](http://www.aimtec.com) for the most current product specifications. 2. Product labels shown, including safety agency certifications on labels, may vary based on the date manufactured. 3. Mechanical drawings and specifications are for reference only. 4. All specifications are measured at an ambient temperature of 25°C, humidity<75%, nominal input voltage and at rated output load unless otherwise specified. 5. Aimtec may not have conducted destructive testing or chemical analysis on all internal components and chemicals at the time of publishing this document. CAS numbers and other limited information are considered proprietary and may not be available for release. 6. This product is not designed for use in critical life support systems, equipment used in hazardous environments, nuclear control systems or other such applications which necessitate specific safety and regulatory standards other the ones listed in this datasheet. 7. Warranty is in accordance with Aimtec's standard Terms of Sale available at [www.aimtec.com](http://www.aimtec.com).