

Click to  
**ORDER**  
samples

## AMED120W-GY



The AMED120W-GY is a DIN-rail mounting AC/DC converter that features a cost-effective and energy efficient design. With an ultra-wide input voltage range of 180-550VAC, the power supply is designed to be powered by single and dual phase power distribution systems and has output voltage range from 12-48V. This converter measures 40.00 x 113.00 x 125.00mm and has ambient air-cooling vents both at the top and bottom of the converter for improved thermal performance.

This series offers great operating temperatures from -25°C to 70°C and features an isolation of 3000VAC for improved reliability and system safety. Furthermore, a high MTBF of 1,300,000h, output short circuit protection (OSCP), output over-load protection (OLP), output over-voltage protection (OVP), and an over temperature protection (OTP) come standard with the series.

The AMED120W-GY is suitable for electric distribution boxes, grid power, instrumentation, CNC machines, industrial control panels and building automation applications.

## Features

- Wide Input: 180 - 550VAC/254 - 780VDC
- Operating Temp: -25 °C to +70 °C
- Isolation voltage: 3000VAC
- Low ripple & noise, 120mV(p-p) and 150mV(p-p)
- Short circuit protection, over-voltage protection, overload protection, and over-temperature protection
- DC OK Signal Output indication
- Designed for dual-phase applications

## Summary

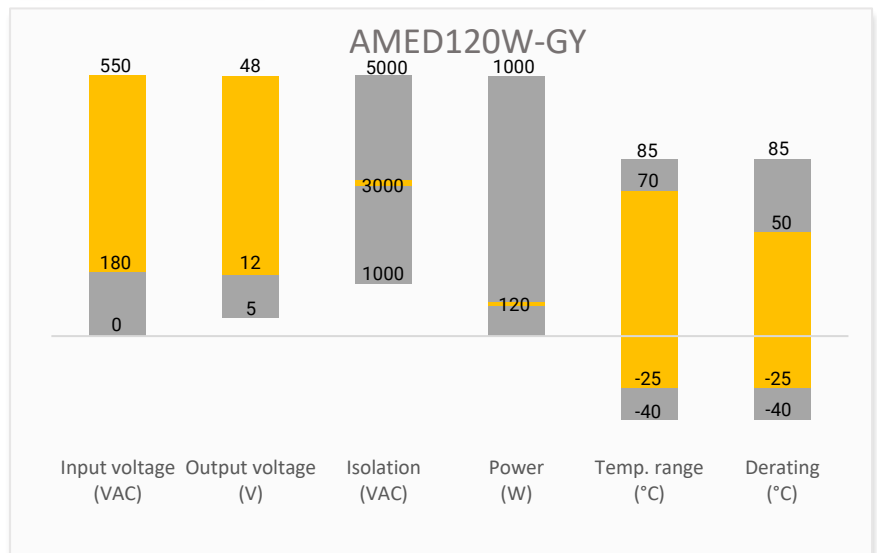

## Training

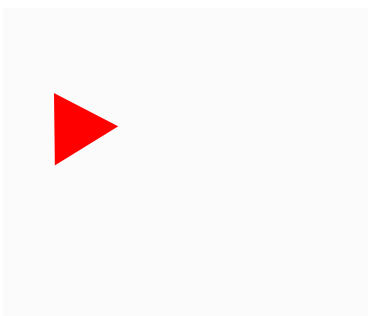

Product Training Video  
(click to open)

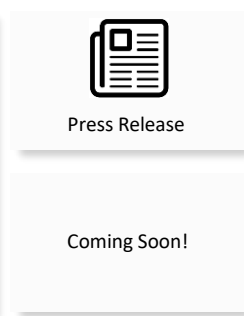

Application Notes

## Applications



Power Grid



Industrial



Telecom

## Models & Specifications

Model	Input Voltage (VAC/Hz)	Input Voltage (VDC)	Max Output wattage (W)	Output Voltage (V)	Output Current max (A)	Efficiency @ 400VAC Typ. (%)
AMED120W-12SGY	180~550/47~63	254~780	120	12	10	89.5
AMED120W-24SGY	180~550/47~63	254~780	120	24	5	91.0
AMED120W-48SGY	180~550/47~63	254~780	120	48	2.5	92.0

### Input Specifications

Parameters	Conditions	Typical	Maximum	Units
Input Current	400VAC	0.7		A
	230VAC	1.2		A
Inrush Current			50	A
Leakage Current	530VAC	<3.5		mA

### Output Specifications

Parameters	Conditions	Typical	Maximum	Units
Voltage accuracy		± 2.0		%
Line regulation	Rated load	± 0.5		%
Load regulation		± 0.5		%
Ripple & Noise*	12 VDC Output		120	mV p-p
	24 VDC Output		120	mV p-p
	48 VDC Output		150	mV p-p
Start-up time	400VAC input, full load		2.0	s
	230VAC input, full load		2.0	s
Rise time	400VAC input, full load		70	ms
	230VAC input, full load		70	ms
Hold up time	400VAC input, full load	50		ms
	230VAC input, full load	10		ms
Voltage adjustable range	12 VDC Output	12 - 15		V
	24 VDC Output	24 - 29		V
	48 VDC Output	48 - 58		V

\* Ripple and Noise are measured at 20MHz bandwidth. Please refer to the application note for specific details. Measured with a 47μF electrolytic capacitor and a 0.1μF ceramic capacitor.

### Isolation Specifications

Parameters	Conditions	Typical	Maximum	Units
Tested I/O voltage	60 sec, Leakage current < 10mA	3000		VAC
Tested Input to GND voltage	60 sec, Leakage current < 10mA	2000		VAC
Tested Output to GND voltage	60 sec, Leakage current < 10mA	500		VAC
Tested Output to P-G signal	60 sec, Leakage current < 2mA	500		VAC
Insulation resistance	I/P to O/P, I/P-FG, O/P-FG, 500VDC, 25°C, 70%RH	100		MΩ

General Specifications				
Parameters	Conditions	Typical	Maximum	Units
Overvoltage category	OVC III			
Over voltage protection	12 VDC Output, manual-recovery	≤ 17.0		VDC
	24 VDC Output, manual-recovery	≤ 33.0		VDC
	48 VDC Output, manual-recovery	≤ 65.0		VDC
Over temperature protection	Output voltage turn off, auto-recovery			
Overload protection	105 ~ 130% rated output power, constant current limiting, auto-recovery			
Short circuit protection	Hiccup, auto-recovery			
Operating temperature	20% ~ 95% RH Non-Condensing	-25 to +70		°C
Storage temperature	10 ~ 95% RH	-40 to +85		°C
Power derating	12 VDC Output, +50 °C to +60°C	4		% / °C
	24, 48 VDC Output, +60 °C to +70°C	4		% / °C
	180VAC - 200VAC	2		% / VAC
Temperature coefficient	0~50°C	± 0.03		% / °C
Cooling	Free air convection			
Storage Humidity	Non-condensing		10~95	% RH
Case material	Metal			
Weight		650		g
Dimensions (L x W x H)	1.57 x 4.45 x 4.92 inches (40.00 x 113.00 x 125.00 mm)			
MTBF	1300K hrs min. Telcordia SR-332 (Bellcore)			
NOTE: All specifications in this datasheet are measured at an ambient temperature of 25°C, humidity<75%, nominal input voltage and at rated output load unless otherwise specified.				

Safety Specifications		
Parameters		
Agency approval	UL61010-1, UL61010-2-201, BS EN/EN62368-1	
Standards	EMC - Conducted and radiated emission	CISPR32 / EN55032, Class B
	Harmonic Current emission	IEC/EN 61000-3-2, Class A
	Voltage Fluctuations & Flicker	IEC/EN 61000-3-3
	Electrostatic Discharge Immunity	IEC/EN 61000-4-2 Contact ±4KV, Air ±8KV, Criteria B
	RF, Electromagnetic Field Immunity	IEC/EN 61000-4-3 3V/m, Criteria A
	Electrical Fast Transient/Burst Immunity	IEC/EN 61000-4-4 ±1KV, Criteria B
	Surge Immunity	IEC/EN 61000-4-5 L-L ±1KV, L-G ±2KV, Criteria B
	CS, Conducted Disturbance Immunity	IEC/EN 61000-4-6 3V, 3V~1V, 1V r.m.s, Criteria A
	Power Frequency Magnetic Field Immunity	IEC/EN 61000-4-8 50, 60Hz, Criteria A
	Voltage dips, Short Interruptions Immunity	IEC/EN 61000-4-11 100% Voltage Dips/Interruptions, 3 cycles, Criteria B

## Derating

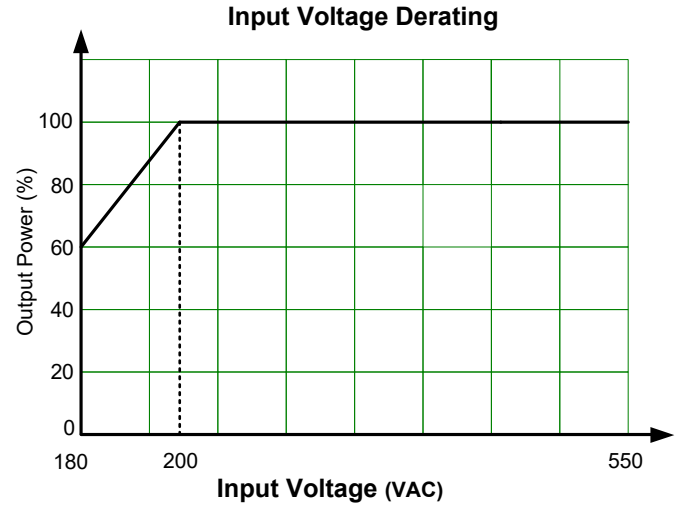
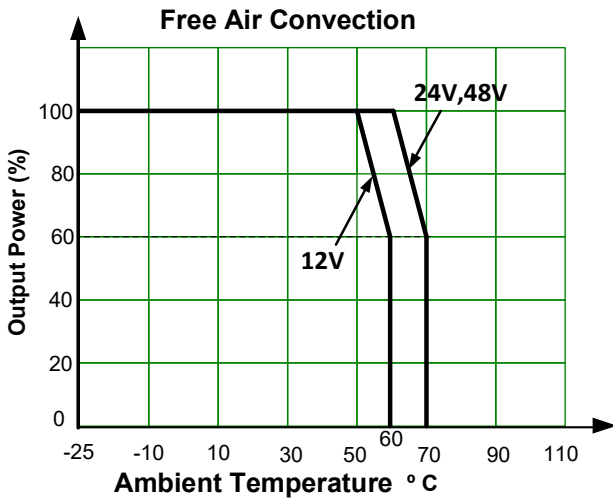

## Functional Diagram

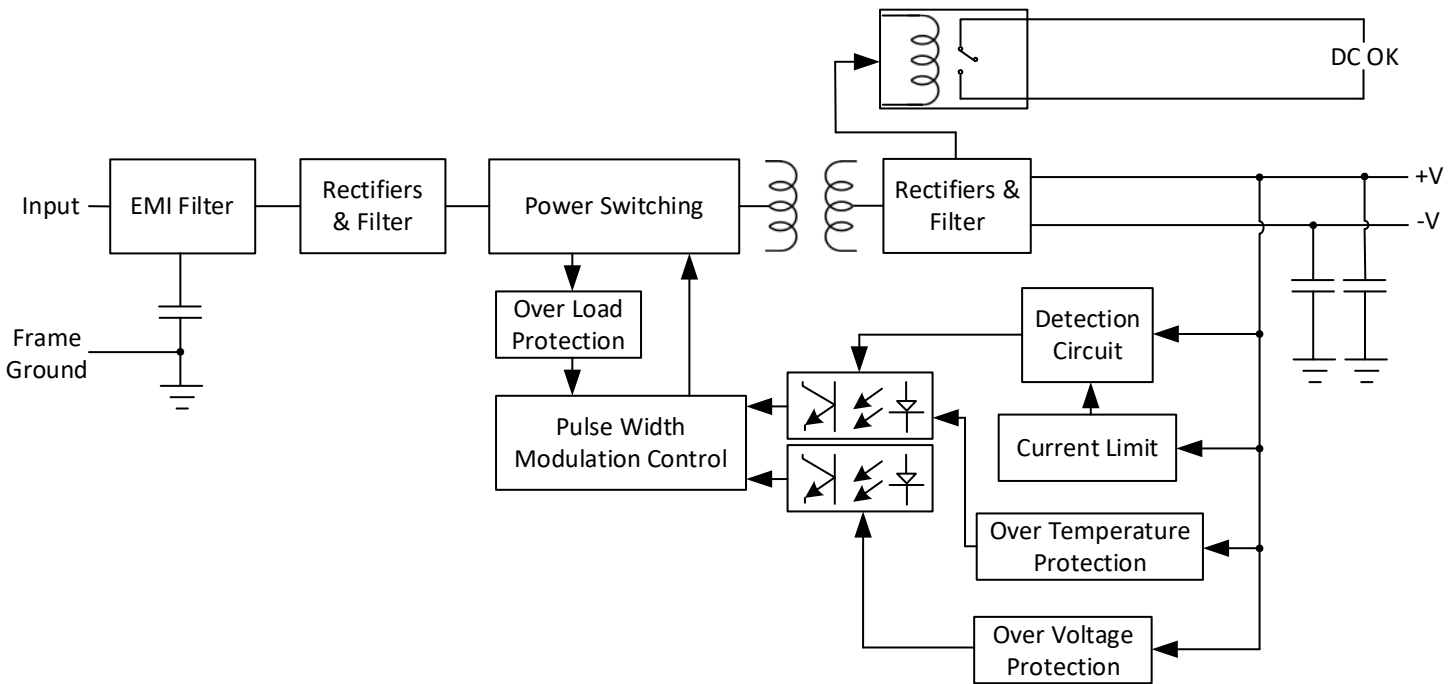

## DC OK Active Signal Application

Contact Closed	Power Supply Unit turns on / DC OK
Contact Open	Power Supply Unit turns off / DC FAIL
Contact Ratings (maximum)	30V/1 A resistive load

## Dimensions

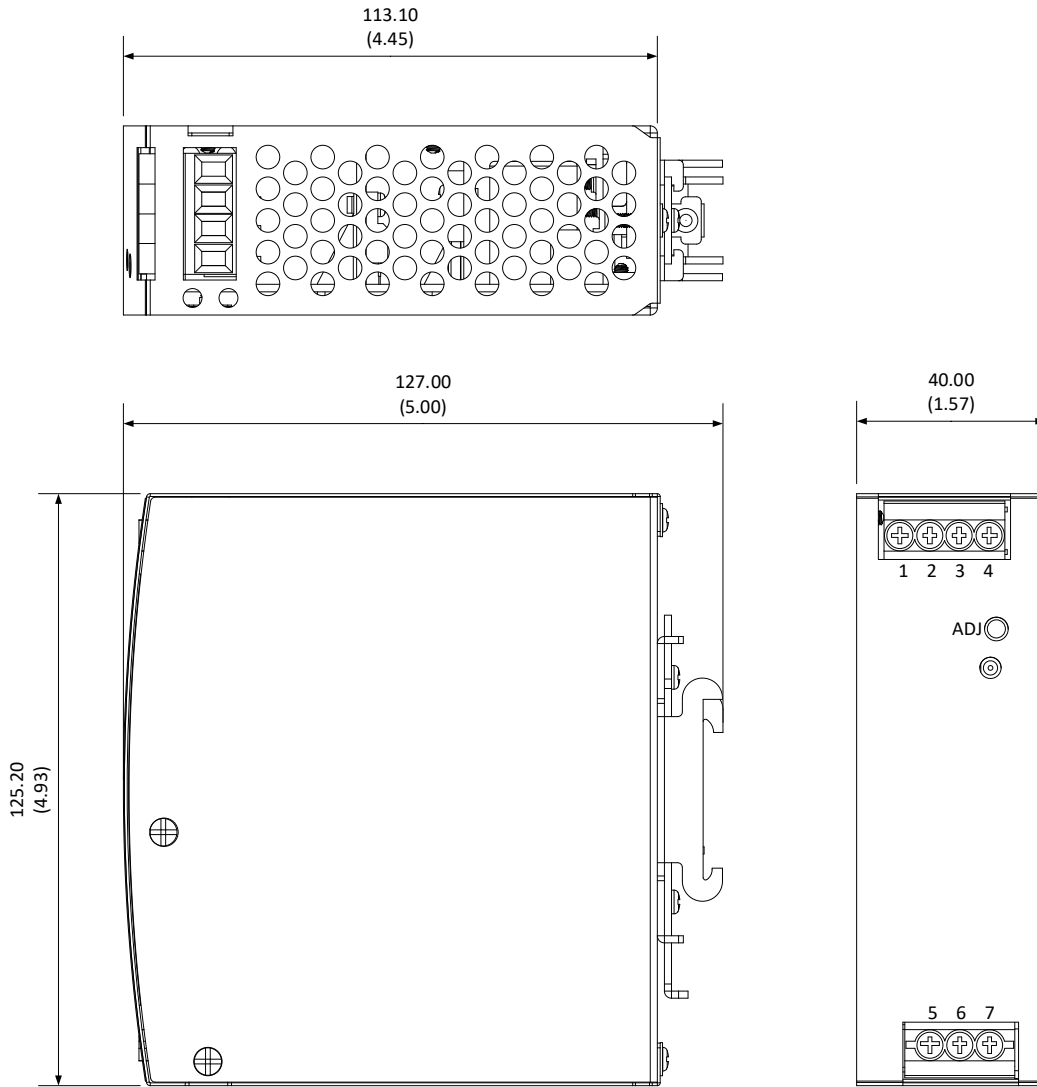

Pin Output Specifications	
Pin	Function
1	Relay Contact
2	Relay Contact
3	-V Output
4	+V Output
5	GND $\equiv$
6	L2
7	L1
ADJ	Voltage Adjustment

**NOTE:** **1.** Datasheets are updated as needed and as such, specifications are subject to change without notice. Once printed or downloaded, datasheets are no longer controlled by Aimtec; refer to [www.aimtec.com](http://www.aimtec.com) for the most current product specifications. **2.** Product labels shown, including safety agency certifications on labels, may vary based on the date manufactured. **3.** Mechanical drawings and specifications are for reference only. **4.** All specifications are measured at an ambient temperature of 25°C, humidity<75%, nominal input voltage and at rated output load unless otherwise specified. **5.** Aimtec may not have conducted destructive testing or chemical analysis on all internal components and chemicals at the time of publishing this document. CAS numbers and other limited information are considered proprietary and may not be available for release. **6.** This product is not designed for use in critical life support systems, equipment used in hazardous environments, nuclear control systems or other such applications which necessitate specific safety and regulatory standards other the ones listed in this datasheet. **7.** Warranty is in accordance with Aimtec's standard Terms of Sale available at [www.aimtec.com](http://www.aimtec.com).