

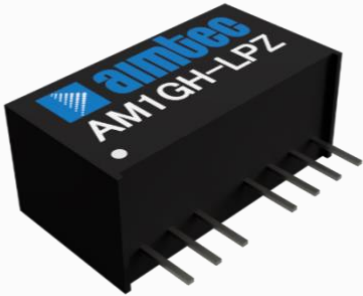

## AM1GH-LPZ



SIP8 Package

The AM1GH-LPZ is a 1W SIP8 DC/DC converter that offers great cost savings thanks to an improved manufacturing process. It also features excellent reliability and performance while offering a wide input voltage range of 4.5-75VDC as well as an output voltage of -15 to 15V. This compact SIP8 design will surely benefit your new system design.

This new series offers a great operating temperature range from -40 to 85°C. Also, an isolation of 3000VDC for improved reliability and system safety as well as a great 1,000,000h MTBF come standard.

The AM1GH-LPZ is suitable for many applications such as industrial systems, portable equipment, and internet of things.

## Features

- High I/O Isolation of 3000VDC
- Input under voltage protection, output over current protection and short circuit protection
- Operating Temp: -40 °C to +85 °C
- Industry standard SIP8 pin-out
- Regulated output

## Summary

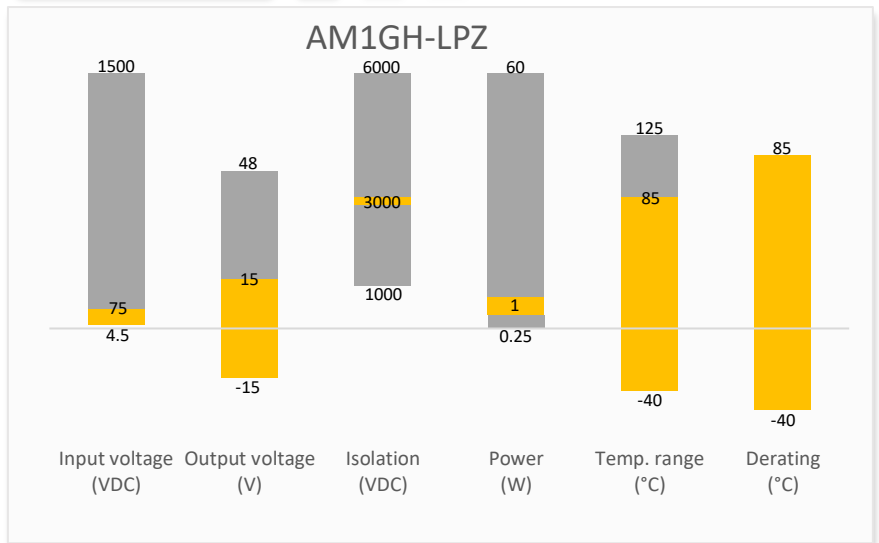

## Training



Product Training Video  
(click to open)



Press Release

Coming Soon!

Application Notes

## Applications



Industrial



Portable Equipment



IoT

## Models & Specifications



### Single Output

Model	Input Voltage (VDC)	Input Current Full/No load Typ. (mA)	Output Voltage (VDC)	Output Current Max/Min (mA)	Isolation (VDC)	Maximum Capacitive Load (μF)	Efficiency Typ. (%)
AM1GH-1203SH30LPZ*	12 (4.5-18)	281/40	3.3	303/16	3000	2700	74
AM1GH-1205SH30LPZ*	12 (4.5-18)	281/40	5	200/10	3000	2200	78
AM1GH-1212SH30LPZ*	12 (4.5-18)	281/40	12	83/5	3000	680	80
AM1GH-1215SH30LPZ*	12 (4.5-18)	281/40	15	67/4	3000	470	80
AM1GH-2403SH30LPZ*	24 (9-36)	111/15	3.3	303/16	3000	2700	75
AM1GH-2405SH30LPZ*	24 (9-36)	111/15	5	200/10	3000	2200	80
AM1GH-2412SH30LPZ*	24 (9-36)	111/15	12	83/5	3000	680	81
AM1GH-2415SH30LPZ*	24 (9-36)	111/15	15	67/4	3000	470	81
AM1GH-4803SH30LPZ	48 (18-75)	55/6	3.3	303/16	3000	2700	74
AM1GH-4805SH30LPZ	48 (18-75)	55/6	5	200/10	3000	2200	79
AM1GH-4812SH30LPZ	48 (18-75)	55/6	12	83/5	3000	680	79
AM1GH-4815SH30LPZ	48 (18-75)	55/6	15	67/4	3000	470	79

### Dual Output

Model	Input Voltage (VDC)	Input Current Full/No load Typ. (mA)	Output Voltage (VDC)	Output Current Max/Min (mA)	Isolation (VDC)	Maximum Capacitive Load (μF)	Efficiency Typ. (%)
AM1GH-1205DH30LPZ*	12 (4.5-18)	281/40	±5	±100/5	3000	±1000	80
AM1GH-1212DH30LPZ*	12 (4.5-18)	281/40	±12	±42/3	3000	±470	80
AM1GH-1215DH30LPZ*	12 (4.5-18)	281/40	±15	±33/2	3000	±330	80
AM1GH-2405DH30LPZ*	24 (9-36)	111/15	±5	±100/5	3000	±1000	79
AM1GH-2412DH30LPZ*	24 (9-36)	111/15	±12	±42/3	3000	±470	80
AM1GH-2415DH30LPZ*	24 (9-36)	111/15	±15	±33/2	3000	±330	81
AM1GH-4805DH30LPZ	48 (18-75)	55/6	±5	±100/5	3000	±1000	79
AM1GH-4812DH30LPZ	48 (18-75)	55/6	±12	±42/3	3000	±470	79
AM1GH-4815DH30LPZ	48 (18-75)	55/6	±15	±33/2	3000	±330	80

### Input Specification

Parameters	Conditions	Typical	Maximum	Units
Maximum rating	1 Sec(max), 12Vin models	> -0.7	25	VDC
	1 Sec (max), 24Vin models	> -0.7	50	VDC
	1 Sec (max), 48Vin models	> -0.7	100	VDC
Under voltage protection	12Vin models	--	4	VDC
	24Vin models	--	8	VDC
	48Vin models	--	16	VDC
Input Reflected Ripple Current		15	--	mA
Remote ON/OFF control	ON	Pin open or logic high (3.5V ~ 12V)		
	OFF	Pin grounded or logic low (0V ~ 0.7V)		
	Ctrl pin current	5	10	mA

Output Specification				
Parameters	Conditions	Typical	Maximum	Units
Voltage accuracy	Full load, 3.3V/5V output	±2	±5	%
	Full load, others	±1	±3	%
Line regulation	Full load, main output	±0.2	±0.5	%
	Full load, other output	±0.5	±1.0	%
Load regulation	5~100% load	±0.5	±1.0	%
Transient response deviation	25% load step	±2.5	±5	%
Transient recovery time	25% load step	500	3000	µS
Ripple & Noise*	20MHz bandwidth	50	150	mV p-p

\* Ripple and Noise are measured at 20MHz bandwidth. Please refer to the application note for specific details.

Isolation Specification				
Parameters	Conditions	Typical	Maximum	Units
Tested I/O voltage	60 sec	3000	--	VDC
Resistance I/O	500VDC	>1000	--	MΩ
Capacitance I/O	100KHz, 0.1V	25	--	pF

General Specifications				
Parameters	Conditions	Typical	Maximum	Units
Switching frequency	Full load	250	--	KHz
Over current protection	Continuous, auto-recovery	>110	--	% Iout
Short circuit protection	Continuous, auto-recovery			
Operating temperature	No derating	-40 to +85	--	°C
Storage temperature		-55 to +125	--	°C
Temperature coefficient	Full load	0.02	0.03	%/°C
Lead Temperature	1.5mm from case for 10 seconds	--	300	°C
Cooling	Free air convection			
Humidity	Non-condensing	>5	95	% RH
Case material	Plastic (UL94V-0)			
Vibration	10-150Hz, 5G, 0.75mm along X, Y and Z			
Weight		4.5	--	g
Dimensions (L x W x H)	0.87 x 0.37 x 0.47 inches (22.00 x 9.50 x 12.00 mm)			
MTBF	1 000 000 hrs (MIL-HDBK -217F, t=+25°C) / Full Load			

NOTE: All specifications in this datasheet are measured at an ambient temperature of 25°C, humidity<75%, nominal input voltage and at rated output load unless otherwise specified.

Safety Specifications		
Parameters		
Agency Approval	UL 62368-1 models marked with * only	
Standards	Designed to meet IEC/EN 62368-1	
	EMC - Conducted and radiated emission	CISPR32/EN55032 Class B with EMC recommended circuit
	Electrostatic Discharge Immunity	IEC/EN 61000-4-2 Contact ±6KV, Criteria B
	RF, Electromagnetic Field Immunity	IEC/EN 61000-4-3 10V/m, Criteria A
	Electrical Fast Transient/Burst Immunity	IEC/EN 61000-4-4 ±2KV, Criteria B with typical application circuit
	Surge Immunity	IEC/EN 61000-4-5 L-L ±2KV, Criteria B with typical application circuit
	RF, Conducted Disturbance Immunity	IEC/EN 61000-4-6 3Vrms, Criteria A

Typical application circuit

Single output

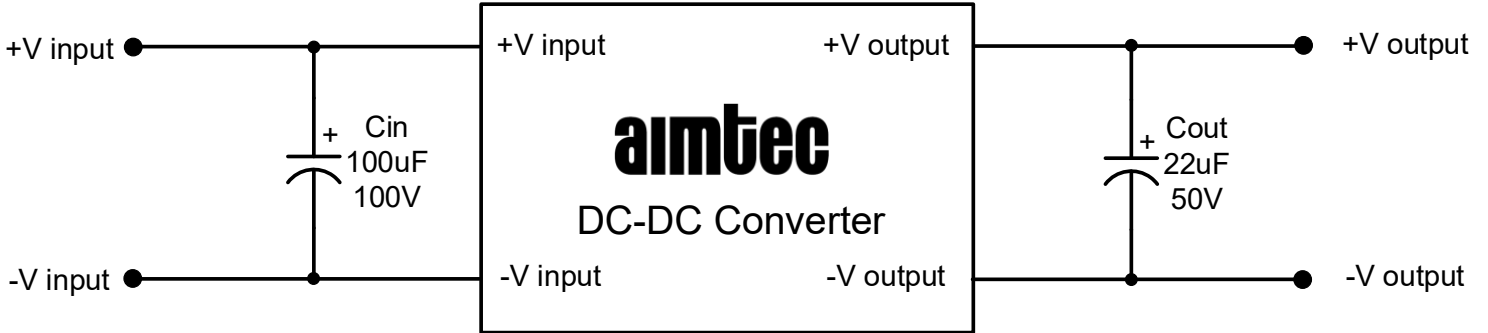

Dual output

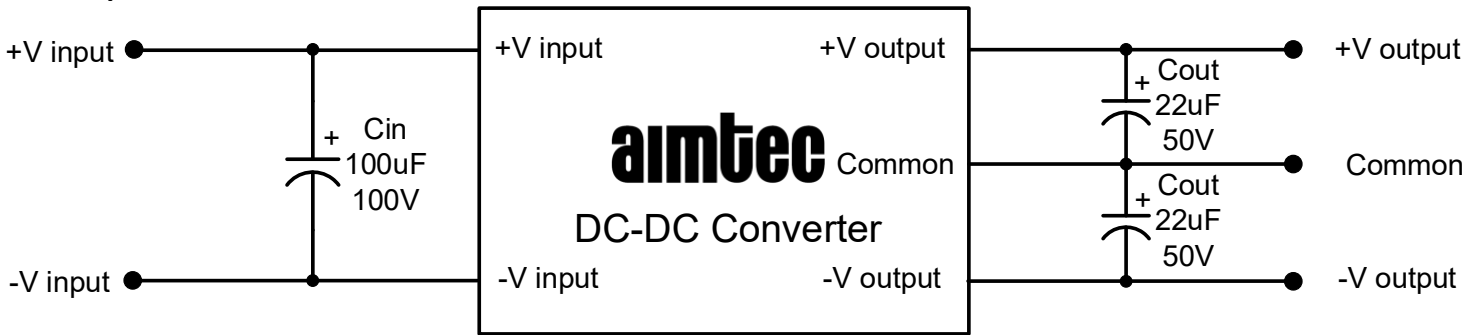

EMC recommended circuit

The recommended circuits are the same for single and dual output models

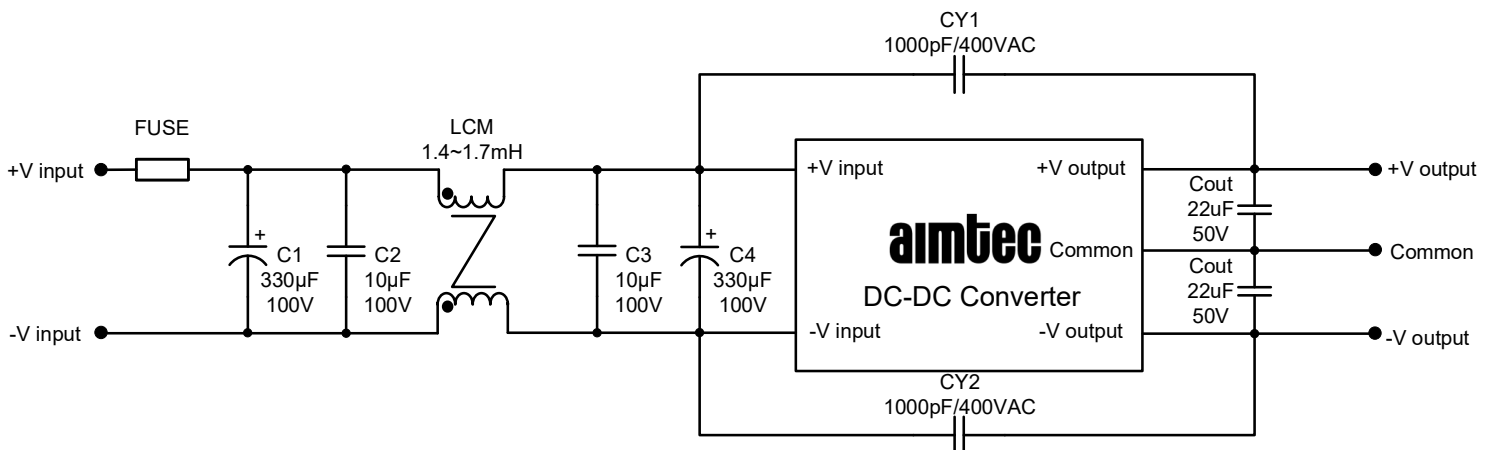

Fuse : Choose according to actual input current.

Dimensions

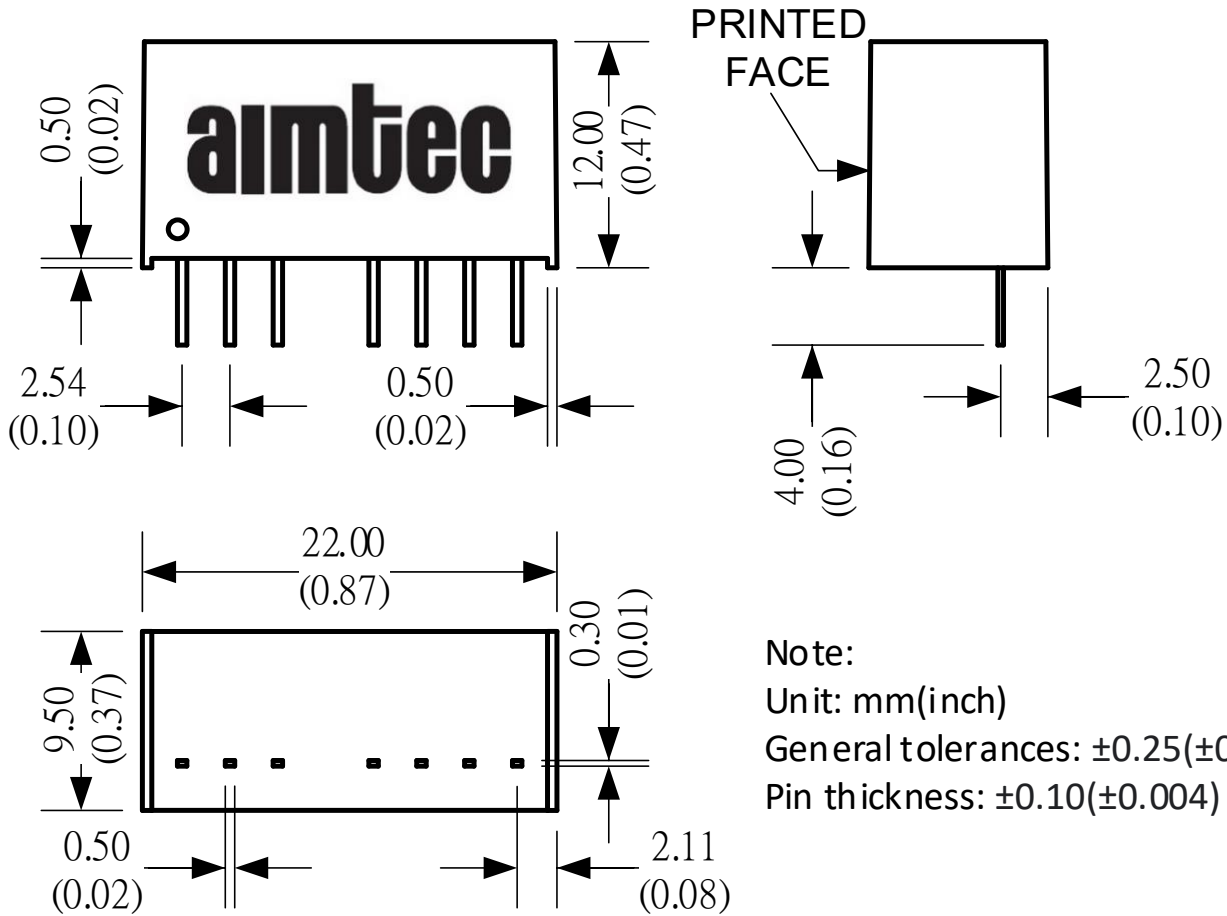

Note:  
Unit: mm(inch)  
General tolerances:  $\pm 0.25(\pm 0.01)$   
Pin thickness:  $\pm 0.10(\pm 0.004)$

Pin Out Specifications		
Pin	Single output	Dual output
1	-V Input	-V Input
2	+V Input	+V Input
3	Remote ON/OFF	Remote ON/OFF
5	N.C.	N.C.
6	+V Output	+V Output
7	-V Output	Common
8	N.C.	-V Output

**NOTE: 1.** Datasheets are updated as needed and as such, specifications are subject to change without notice. Once printed or downloaded, datasheets are no longer controlled by Aimtec; refer to [www.aimtec.com](http://www.aimtec.com) for the most current product specifications. **2.** Product labels shown, including safety agency certifications on labels, may vary based on the date manufactured. **3.** Mechanical drawings and specifications are for reference only. **4.** All specifications are measured at an ambient temperature of 25°C, humidity<75%, nominal input voltage and at rated output load unless otherwise specified. **5.** Aimtec may not have conducted destructive testing or chemical analysis on all internal components and chemicals at the time of publishing this document. CAS numbers and other limited information are considered proprietary and may not be available for release. **6.** This product is not designed for use in critical life support systems, equipment used in hazardous environments, nuclear control systems or other such applications which necessitate specific safety and regulatory standards other the ones listed in this datasheet. **7.** Warranty is in accordance with Aimtec's standard Terms of Sale available at [www.aimtec.com](http://www.aimtec.com).