

Click to
ORDER
samples

AMESP350U-277NZ

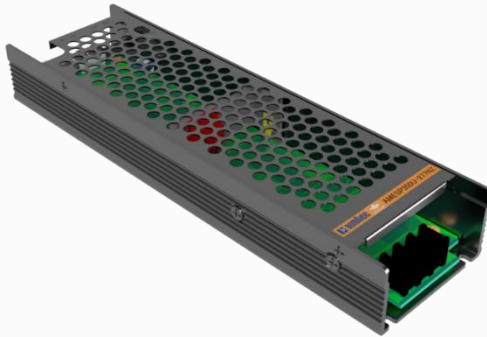

Enclosed

The AMESP350U-277NZ series is an efficient, enclosed, fan less, ultra-narrow, and semi-potted 350W AC/DC power supply module. It offers a wide commercial input voltage range of 90-305VAC, output voltage ranges from 3.3-55V, low power consumption, high efficiency, high reliability, and safer isolation.

This new series offers great operating temperatures, from -30°C to +70°C with full power up to 50°C and features an isolation of 3750VAC with improved reliability and system safety. Furthermore, a high MTBF of 188,400h, output short circuit protection (OSCP), output over-current protection (OCP), output over-voltage protection (OVP), and over temperature protection (OTP) come standard with the series.

The AMESP350U-277NZ is suitable for street lighting controls, grid power, instrumentation, industrial controls, communication, and civil applications.

Features

- Universal Input: 90 - 305VAC/127 - 430VDC
- Operating Temp: -30°C to +70°C
- High isolation voltage: 3750VAC
- Active PFC
- Output short circuit, over-current, over-voltage, over-temperature protection
- Efficiency up to 91%
- DC OK active signal and redundant function (option)

Summary

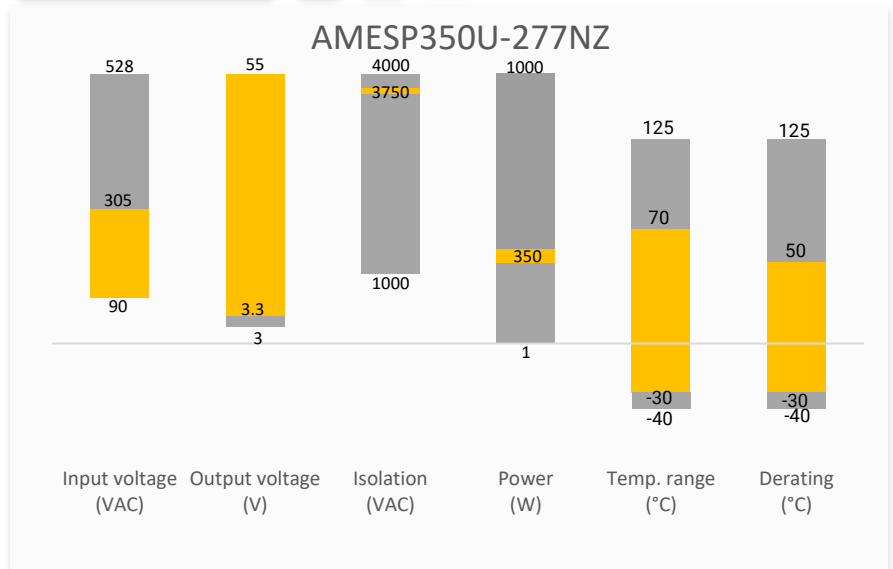

Training



Product Training Video



Press Release

Coming Soon!

Application Notes

Applications



Power Grid



Industrial



Telecom

Models & Specifications



Single Output

Model	Input Voltage (VAC/Hz)	Input Voltage (VDC)	Max Output Wattage (W)	Output Voltage (V)	Output Voltage Adjustable Range (V)	Output Current max (A)	Maximum capacitive load (μ F)	Average Efficiency (%)
AMESP350U-3S277NZ-P	90-305/50-60	127-430	198	3.3	3.2-3.5	60	12000	88
AMESP350U-4S277NZ-P	90-305/50-60	127-430	252	4.2	3.6-4.4	60	12000	89
AMESP350U-5S277NZ-P	90-305/50-60	127-430	300	5	4.5-5.5	60	12000	89
AMESP350U-12S277NZ-P	90-305/50-60	127-430	350.4	12	11.4-12.6	29.2	10000	90
AMESP350U-15S277NZ-P	90-305/50-60	127-430	351	15	14.3-15.8	23.4	9000	90
AMESP350U-24S277NZ-P	90-305/50-60	127-430	350.4	24	22.8-25.2	14.6	8000	90
AMESP350U-36S277NZ-P	90-305/50-60	127-430	351	36	34.2-37.8	9.75	6000	90
AMESP350U-48S277NZ-P	90-305/50-60	127-430	350.4	48	45.6-50.4	7.3	4000	91
AMESP350U-55S277NZ-P	90-305/50-60	127-430	352	55	45-58	6.4	3000	91

Note: The “-P” suffix indicates a terminal protective cover (ex. AMESP350U-12S277NZ-P). For optional conformal coating, add “Q” after the “-P” (ex. AMESP350U-12S277NZ-PQ is conformal coated version with terminal protective cover). For optional built-in DC ok active signal and redundant function, add “R” after the “-P” (ex. AMESP350U-12S277NZ-PR is the built in DC ok signal and redundant function version with terminal protective cover).

Input Specifications

Parameters	Conditions	Typical	Minimum	Maximum	Units
Input current	115VAC			4.6	A
	230VAC			2.3	A
Inrush current	Cold Start, 115VAC	30			A
	Cold Start, 230VAC	60			A
Leakage	240VAC			<0.75	mA
Power Factor	Full Load, 115VAC	0.98			
	Full Load, 230VAC	0.94			

Output Specifications

Parameters	Conditions	Typical	Maximum	Units
Voltage accuracy	Full Load Range, 3.3V / 4.2V / 5V output	± 2		%
	Full Load Range, others	± 1		%
Line regulation	Rated Load, 3.3V / 4.2V / 5V output	± 0.5		%
	Rated Load, others	± 0.3		%
Load Regulation	0%-100% Load, 3.3V / 4.2V / 5V output	± 1		%
	0%-100% Load, others	± 0.5		%
Ripple & Noise*	3.3V, 4.2V output		150	mV p-p
	5V, 12V, 15V output		200	mV p-p
	24V, 36V, 48V output		240	mV p-p
	55V output		300	mV p-p
Hold up time	Full Load, 115VAC/230VAC	10		ms

* Ripple and Noise are measured at 20MHz bandwidth with a 47 μ F electrolytic capacitor and a 0.1 μ F ceramic capacitor. Please refer to the application note for specific details.

Isolation Specifications

Parameters	Conditions	Typical	Rated	Units
Tested I/O voltage	60 sec		3750	VAC
Tested Input to GND voltage	60 sec		2000	VAC
Tested Output to GND voltage	60 sec		1250	VAC
Resistance (I/O, I/O to GND) *	500VDC		100	MΩ

* Tested under 25±5°C ambient temperature with relative humidity <95% and no condensation.

General Specifications

Parameters	Conditions	Typical	Minimum	Maximum	Units
Safety class	Class I				
Over voltage category	OVC III / According to EN62368-1; altitude up to 2000 meters				
Over current protection	Hiccup, Auto recovery		110	140	% of Iout
Over voltage protection	Shut-down, Manual recovery		115	135	% of Vout
Over temperature protection	Shut down o/p voltage, recovers automatically after temperature goes down.				
Short circuit protection	Hiccup, Continuous, Auto recovery				
Operating temperature	See derating graph		-30	+70	°C
Storage temperature			-40	+85	°C
Power Derating	50°C to 70°C, Conduction	2			%/°C
	45°C to 70°C, Convection, 110VAC	1.2			%/°C
	45°C to 70°C, Convection, 230VAC 3.3V, 4.2V, 5V	1.6			%/°C
	50°C to 70°C, Convection, 230VAC 55V	2.5			%/°C
	50°C to 70°C, Convection, 230VAC others	3			%/°C
	90VAC ~ 110VAC	1.25			%/VAC
Temperature coefficient	0 ~ 50 °C	±0.03			% / °C
Cooling	Free air convection				
Operating humidity	Non-condensing		20	95	% RH
Storage humidity	Non-condensing		10	95	% RH
Case material	Metal				
Weight		700			g
Dimensions (L x W x H)	8.74 x 2.44 x 1.22 inches (222.00 x 62.00 x 31.00 mm)				
Vibration	10 ~ 500Hz, 5G 10min./1cycle, 60min. each along X, Y, Z axes				
MTBF	> 188 400 hrs MIL-HDBK-217(25°C)				

NOTE: All specifications in this datasheet are measured at an ambient temperature of 25°C, humidity<75%, nominal input voltage and at rated output load unless otherwise specified.

Safety Specifications

Parameters		
Agency approvals	UL62368-1	
Standards	Over voltage category	Designed to meet III; According to EN62368-1
	Information technology Equipment	Designed to meet EN62368-1, BS EN62368-1, EN60335-1, EN61558-1
	EMC - Conducted and radiated emission	CISPR32 / EN55032, class B
	Harmonic current	IEC 61000-3-2
	Voltage flicker	IEC 61000-3-3
	Electrostatic Discharge Immunity	IEC/EN61000-4-2 Criteria A
	RF, Electromagnetic Field Immunity	IEC/EN61000-4-3 Criteria A
	Electrical Fast Transient/Burst Immunity	IEC/EN61000-4-4 Criteria A
	Surge Immunity	IEC/EN61000-4-5 Criteria A
	RF, Conducted Disturbance Immunity	IEC/EN61000-4-6 Criteria A
	Power Frequency Magnetic Field	IEC/EN61000-4-8 Criteria A
	Voltage dips, Short Interruptions Immunity	IEC/EN61000-4-11 Criteria B

Derating

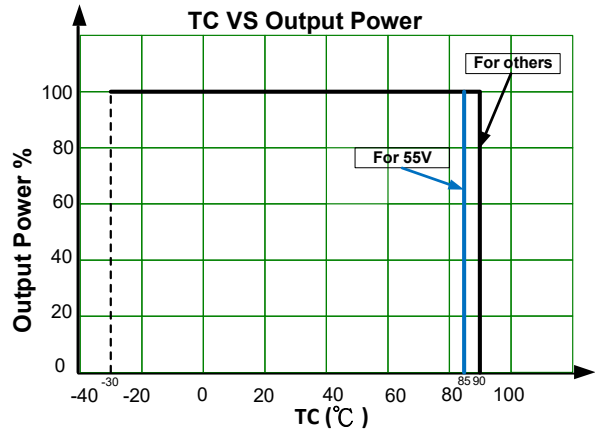
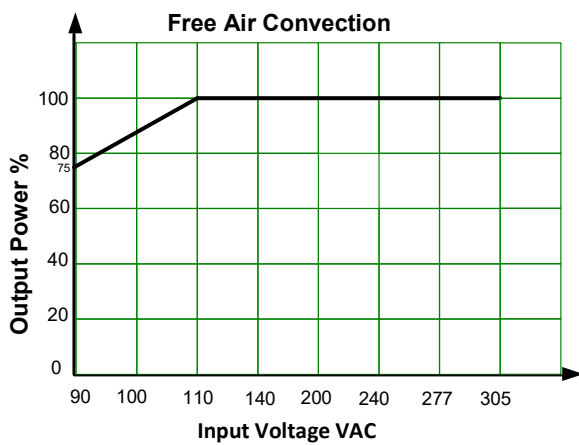
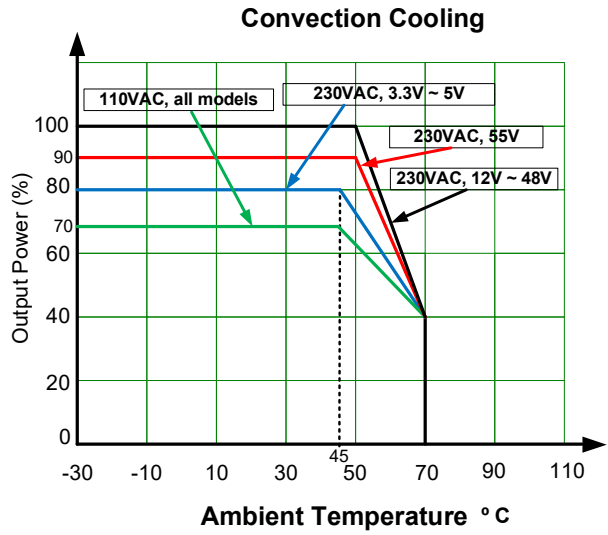
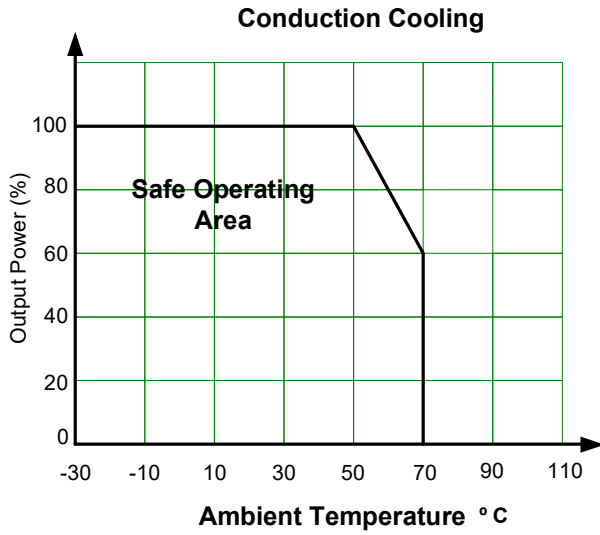

Please refer to Dimension for the TC position.

Dimensions

Pin Output Specifications	
Pin	Single
1	PE GND
2	AC Input (N)
3	AC Input (L)
4	+V Output
5	+V Output
6	-V Output
7	-V Output



CN1 (DC OK connector) DL20001-AWD or equivalent	
Pin	Single
1	-V _{DC} OK
2	+V _{DC} OK

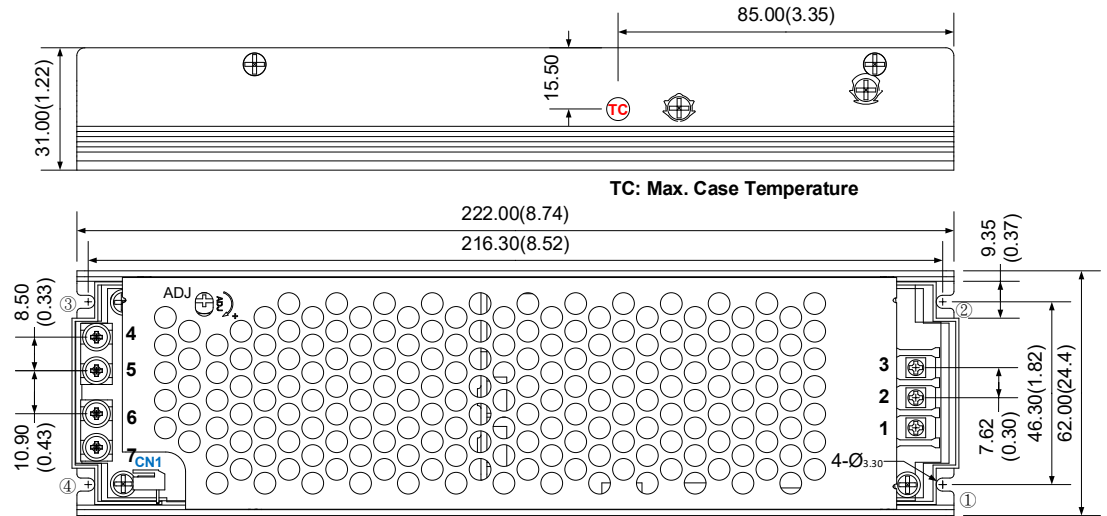

Note:
Unit: mm(inch)
General tolerance: $\pm 1.0(0.04)$

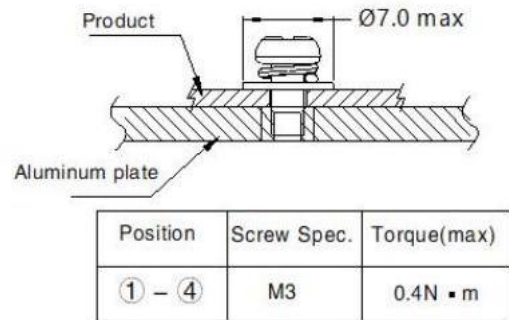
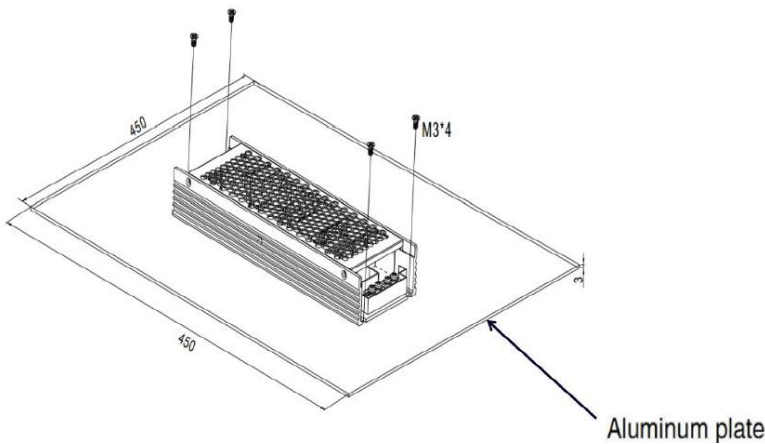

- Note:
- Operate with additional aluminum plate to meet the "Derating Curve" and the "Static Characteristics", the series model must be installed onto an aluminum plate (or the cabinet of the same size) on the bottom. The size of the suggested aluminum plate is 450mm x 450mm. And for optimizing thermal performance, the aluminum plate must have an even and smooth surface (or coated with thermal grease), and the series model must be firmly mounted at the center of the aluminum plate.
 - It is suggested to install the product with M3 combination screws, and the product must be firmly installed at the center of the aluminum plate.

Block Diagram

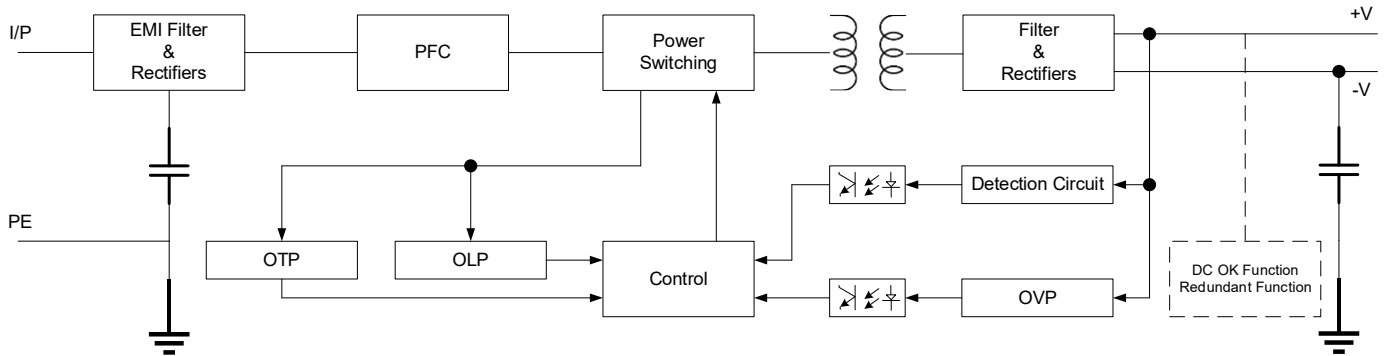

Function

DC OK Signal (Option)	Contact rating (max.): 15VDC/10mA resistive load
Redundant (Option)	For parallel applications, if one power supply unit (PSU) fails, the other will automatically take over. This ensures continuous operation, prevents system crashes, and enhances overall system reliability.

Function Manual

1. DC OK Signal

The DC OK signal is an open-collector output, typically implemented using an optocoupler inside the power supply. It indicates the output status of the power supply, as shown below.

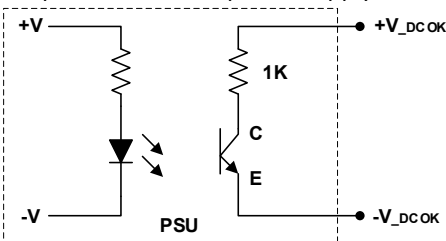

Optocoupler C-E Pin Conduction	PSU turns on	DC OK
Optocoupler C-E Pin Open	PSU turns off	DC Fail
Optocoupler Rating (Max.)	15VDC/10mA resistive load	

2. Redundant Function

- AMESP350U-XXS277NZ-PR features a built-in redundancy function and supports parallel connection of two units.
- During parallel operation, the total load should not exceed the rated power of a single power supply unit (PSU).

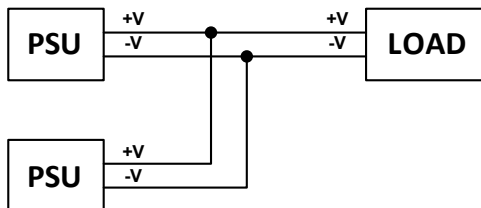

NOTE: 1. Datasheets are updated as needed and as such, specifications are subject to change without notice. Once printed or downloaded, datasheets are no longer controlled by Aimtec; refer to www.aimtec.com for the most current product specifications. 2. Product labels shown, including safety agency certifications on labels, may vary based on the date manufactured. 3. Mechanical drawings and specifications are for reference only. 4. All specifications are measured at an ambient temperature of 25°C, humidity<75%, nominal input voltage and at rated output load unless otherwise specified. 5. Aimtec may not have conducted destructive testing or chemical analysis on all internal components and chemicals at the time of publishing this document. CAS numbers and other limited information are considered proprietary and may not be available for release. 6. This product is not designed for use in critical life support systems, equipment used in hazardous environments, nuclear control systems or other such applications which necessitate specific safety and regulatory standards other the ones listed in this datasheet. 7. Warranty is in accordance with Aimtec's standard Terms of Sale available at www.aimtec.com.