

**AMEL30-GY**

Click to  
**ORDER**  
samples



Encapsulated

The AMEL30-GY series is an efficient 30W AC-DC power supply module. Offering a commercial input voltage range of 90-264VAC, output voltage ranges from 5-48V, low power consumption, high efficiency, high reliability and safer isolation.

This new series offers great operating temperatures, from -30°C to 70°C with full power up to 50°C and features an isolation of 4000VAC for improved reliability and system safety. Furthermore, a high MTBF of 600,000h, output short circuit protection (OSCP), output over-current protection (OCP) and an output over-voltage protection (OVP) come standard with the series.

The AMEL30-GY is suitable for grid power, industrial instrumentation and controls, communication, and civil applications.

**Features**

- Universal Input: 90 - 264VAC
- Operating Temp: -30 °C to +70 °C
- High isolation voltage: 4000VAC
- Output short circuit, over-current, over-voltage protection
- Low no-load power consumption of 0.1W
- Agency approvals: IEC/EN/UL62368-1



**Summary**

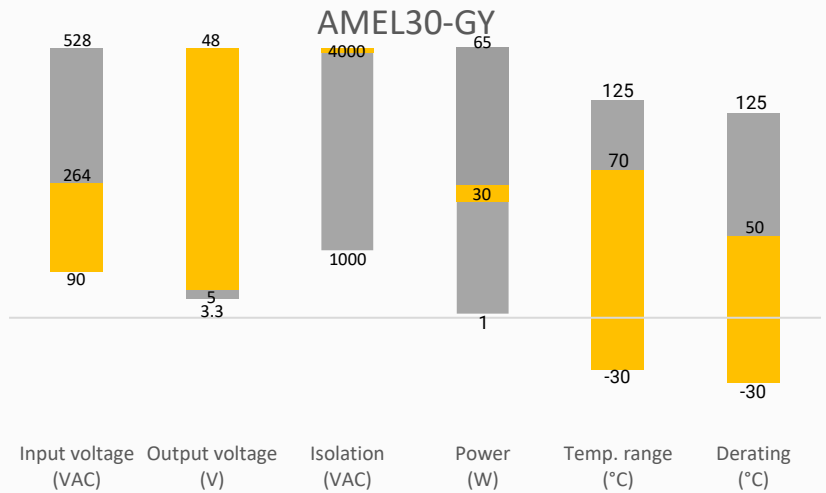

**Training**

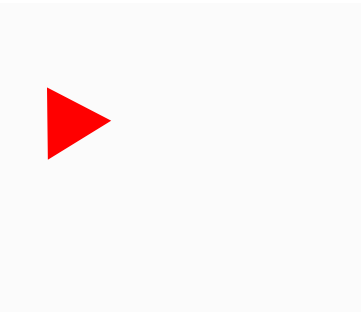

Product Training Video  
(click to open)

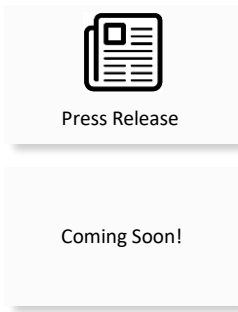

Application Notes

**Applications**



Power Grid



Industrial



Telecom

## Models & Specifications

### Single Output

Model	Input Voltage (VAC/Hz)	Max Output wattage (W)	Output Voltage (V)	Output Current max (A)	Maximum capacitive load ( $\mu$ F)	AVG. Efficiency (%)
AMEL30-5SGY	90-264/47-63	30	5	6	6000	83
AMEL30-12SGY	90-264/47-63	30	12	2.5	4400	88
AMEL30-15SGY	90-264/47-63	30	15	2	3300	88
AMEL30-24SGY	90-264/47-63	30	24	1.25	700	88
AMEL30-48SGY	90-264/47-63	30	48	0.63	470	90

Note: Use suffix "ST" for chassis mounting (ex. AMEL30-5SGY-ST is chassis mounting version).

### Input Specifications

Parameters	Conditions	Typical	Maximum	Units
Input current	115VAC	0.75		A
	230VAC	0.5		A
Inrush current	115VAC, cold start	25		A
	230VAC, cold start	45		A
Leakage	264VAC, 50Hz		0.25	mA

### Output Specifications

Parameters	Conditions	Typical	Maximum	Units
Voltage accuracy		$\pm 2$		%
Line regulation	Full load	$\pm 0.5$		%
Load regulation	5Vout	$\pm 1$		%
	others	$\pm 0.5$		%
Ripple & Noise*	20MHz bandwidth, 5Vout		120	mV p-p
	20MHz bandwidth, 12Vout		150	mV p-p
	20MHz bandwidth, 15Vout		200	mV p-p
	20MHz bandwidth, 24Vout		240	mV p-p
	20MHz bandwidth, 48Vout		300	mV p-p
Hold up time	115VAC	10		ms
	230VAC	40		ms

\* Ripple and Noise are measured at 20MHz bandwidth with a 47 $\mu$ F electrolytic capacitor and a 0.1 $\mu$ F ceramic capacitor. Please refer to the application note for specific details.

### Isolation Specification

Parameters	Conditions	Typical	Maximum	Units
Tested I/O voltage	60 sec	>4000		VAC
Resistance I/O	500VDC, 25°C, 70% RH	>100		M $\Omega$

General Specifications				
Parameters	Conditions	Typical	Maximum	Units
Protection class	Class II			
Overvoltage category	OVC III according to EN62368-1			
Over current protection	Hiccup, Auto recovery	≥ 115	160	% of Iout
Over voltage protection	5Vout, shut off o/p voltage, clamping by Zener diode		7.5	VDC
	12Vout, shut off o/p voltage, clamping by Zener diode		16.5	VDC
	15Vout, shut off o/p voltage, clamping by Zener diode		24	VDC
	24Vout, shut off o/p voltage, clamping by Zener diode		34	VDC
	48Vout, shut off o/p voltage, clamping by Zener diode		65	VDC
Short circuit protection	Hiccup, Continuous, Auto recovery			
Operating temperature	See derating graph	-30 to +70		°C
Storage temperature		-40 to +85		°C
Wave soldering temperature	Duration 5s max.	265		°C
Manual soldering temperature	Duration 3s max.	390		°C
No-load power consumption			0.1	W
Power Derating	+40 °C to +70 °C, 5Vout 100VAC	1.67		%/°C
	+45 °C to +70 °C, 5Vout 230VAC	2		%/°C
	+50 °C to +70 °C, others 100 & 230VAC	2.5		%/°C
	90VAC to 100VAC	2		%/VAC
Temperature coefficient	(0~50°C)	±0.03		%/°C
Cooling	Free air convection			
Humidity	Non-condensing, Storage	10	95	% RH
	Non-condensing, Operating	20	90	% RH
Vibration	PCB mountable model: 10 ~ 500Hz, 2G 10min. /1cycle, period for 60min. each along X, Y, Z axes With optional -ST mounting plate: 10 ~ 500Hz, 5G 10min. /1cycle, period for 60min. each along X, Y, Z axes			
Case material	Black Plastic (flame retardant and heat resistant)			
Weight	PCB mountable models	94		g
	With optional -ST mounting plate	113		
Dimensions (L x W x H)	PCB mountable models	2.74 x 1.54 x 0.94 inches (69.5 x 39 x 24 mm)		
	With optional -ST mounting plate	3.58 x 1.56 x 1.12 inches (91 x 39.5 x 28.5 mm)		
MTBF	> 600 000 hrs (MIL-HDBK -217F, t=+25°C)			
NOTE: All specifications in this datasheet are measured at an ambient temperature of 25°C, humidity<75%, nominal input voltage and at rated output load unless otherwise specified.				

Safety Specifications		
Parameters		
Agency Approvals	IEC/EN/UL62368-1	
Standards	EMI - Conducted and radiated emission	BS EN/EN55032(CISPR32) class B
	Limits for Harmonic current emissions	IEC/EN 61000-3-2, class A
	Voltage fluctuations and flicker	IEC/EN 61000-3-3
	Electrostatic Discharge Immunity	IEC/EN 61000-4-2, Contact ±4KV, Air ±8KV, Criteria A
	RF, Electromagnetic Field Immunity	IEC/EN 61000-4-3, Level 3, Criteria A
	Electrical Fast Transient/Burst Immunity	IEC/EN 61000-4-4, Level 3, Criteria A
	Surge Immunity	IEC/EN 61000-4-5, ±2KV/L-N, Criteria A
	RF, Conducted Disturbance Immunity	IEC/EN 61000-4-6, Level 3, Criteria A
	Magnetic field immunity	IEC/EN 61000-4-8, Level 4, Criteria A
	Voltage Dips and interruptions	IEC/EN 61000-4-11, >95% dip 0 5 periods, 30% dip 25 periods,>95% interruptions 250

Derating

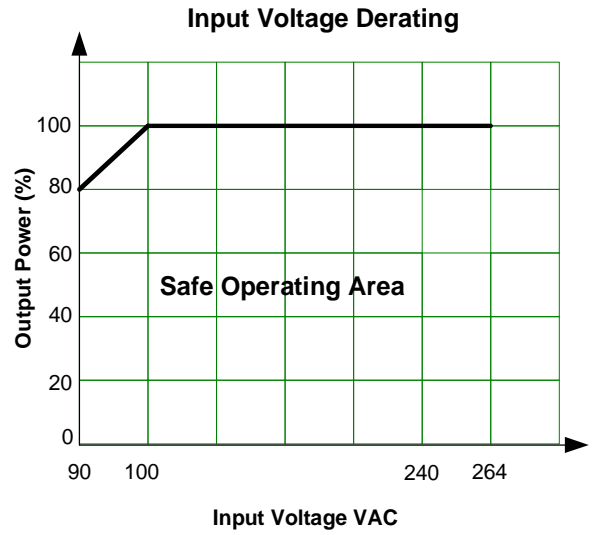
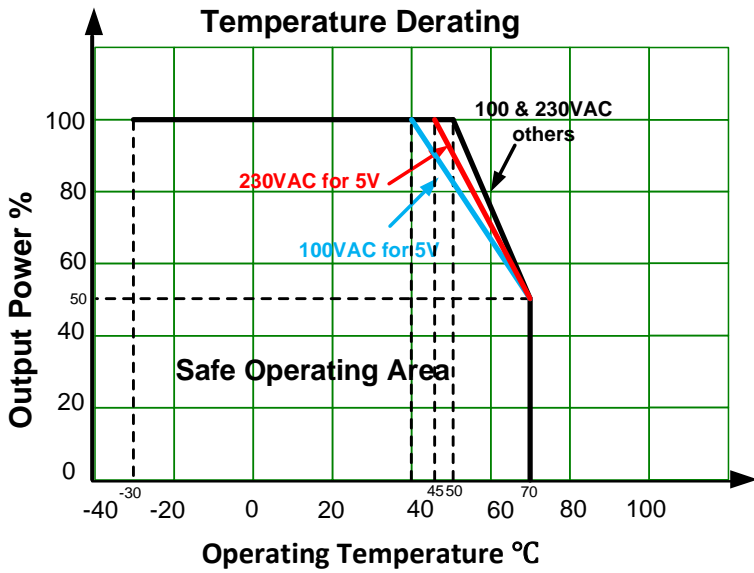

## Dimensions

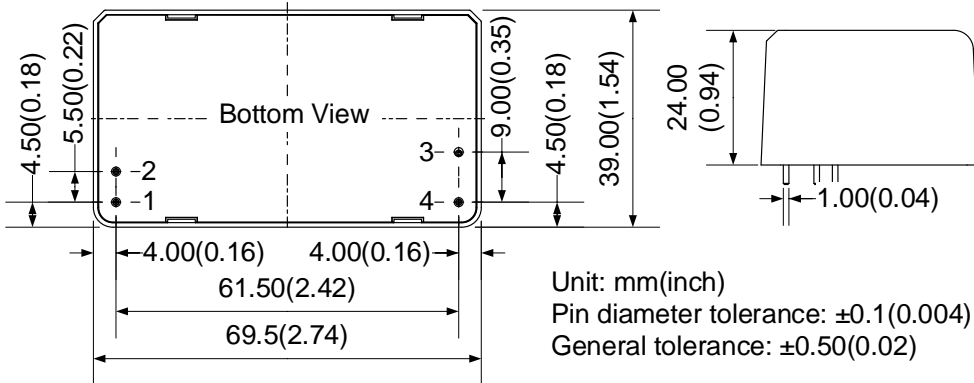

## Dimensions with Optional - ST

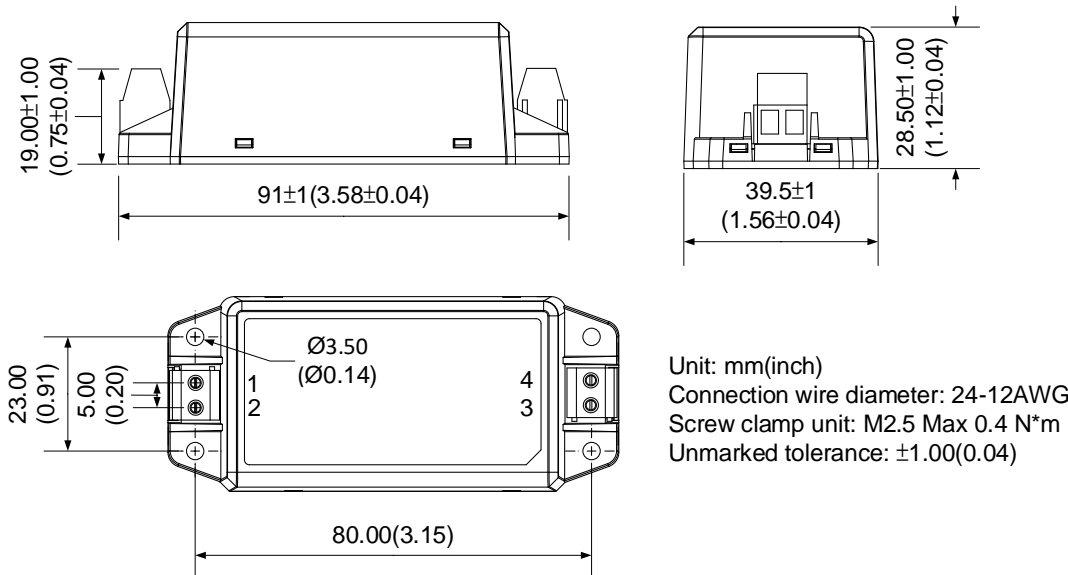

Pin Output Specifications	
Pin	Single
1	AC Input (L)
2	AC Input (N)
3	+V Output
4	-V Output

**NOTE:** 1. Datasheets are updated as needed and as such, specifications are subject to change without notice. Once printed or downloaded, datasheets are no longer controlled by Aimtec; refer to [www.aimtec.com](http://www.aimtec.com) for the most current product specifications. 2. Product labels shown, including safety agency certifications on labels, may vary based on the date manufactured. 3. Mechanical drawings and specifications are for reference only. 4. All specifications are measured at an ambient temperature of 25°C, humidity < 75%, nominal input voltage and at rated output load unless otherwise specified. 5. Aimtec may not have conducted destructive testing or chemical analysis on all internal components and chemicals at the time of publishing this document. CAS numbers and other limited information are considered proprietary and may not be available for release. 6. This product is not designed for use in critical life support systems, equipment used in hazardous environments, nuclear control systems or other such applications which necessitate specific safety and regulatory standards other than the ones listed in this datasheet. 7. Warranty is in accordance with Aimtec's standard Terms of Sale available at [www.aimtec.com](http://www.aimtec.com).