

Click to  
**ORDER**  
samples

**AMEL30-277HAGY**



Encapsulated

The AMEL30-277HAGY series is an efficient 30W AC-DC power supply module. Offering a commercial input voltage range of 85-305VAC, output voltage ranges from 5-48V, low power consumption, high efficiency, high reliability and safer isolation.

This new series offers great operating temperatures, from -30°C to 85°C with full power up to 50°C and features an isolation of 3000VAC for improved reliability and system safety. Furthermore, a high MTBF of 654,700h, output short circuit protection (OSCP), output over-current protection (OCP) and an output over-voltage protection (OVP) come standard with the series.

The AMEL30-277HAGY is suitable for grid power, industrial instrumentation and controls, communication, and civil applications.

**Features**



- Universal Input: 85 - 305VAC/120 – 430VDC
- Operating Temp: -30 °C to +85 °C
- High isolation voltage: 3000VAC
- Output short circuit, over-current, over-voltage protection
- Low no-load power consumption of 0.1W max.
- Agency approval: UL62368-1
- Designed to meet: IEC/EN62368-1, EN60335-1, EN62233

**Summary**

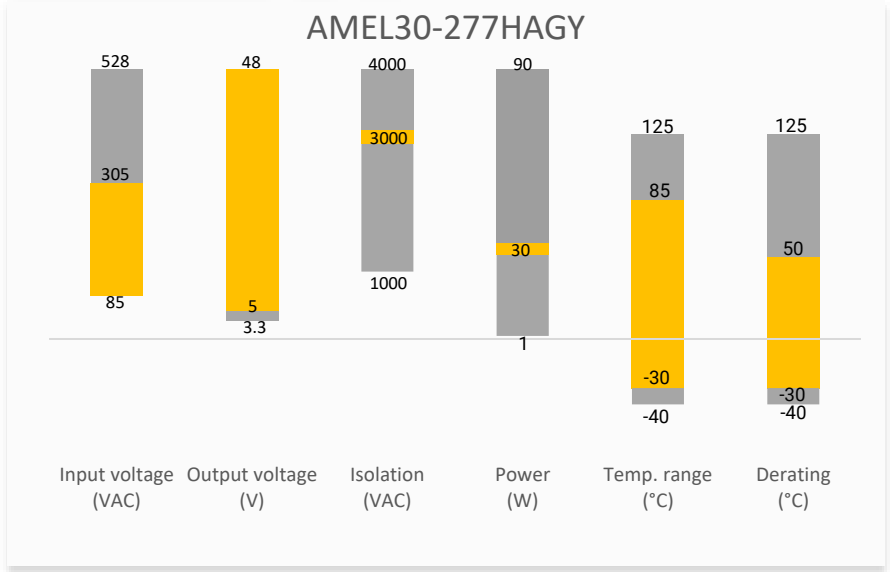

**Training**

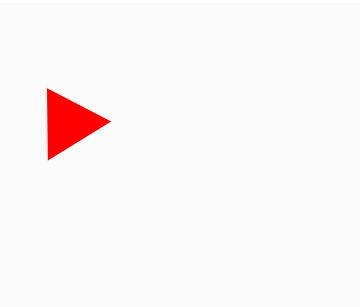

Product Training Video  
(click to open)



Application Notes

**Applications**



Power Grid



Industrial



Telecom

## Models & Specifications

### Single Output

Model	Input Voltage (VAC/Hz)	Input Voltage (VDC)	Max Output wattage (W)	Output Voltage (V)	Output Current max (A)	Maximum capacitive load (μF)	Average Efficiency (%)
AMEL30-5S277HAGY	85-305/47-63	120-430	30	5	6	6000	85
AMEL30-12S277HAGY	85-305/47-63	120-430	30	12	2.5	4400	87
AMEL30-15S277HAGY	85-305/47-63	120-430	30	15	2	3300	87
AMEL30-24S277HAGY	85-305/47-63	120-430	30	24	1.25	700	87
AMEL30-48S277HAGY	85-305/47-63	120-430	30	48	0.625	470	88

Note: Use suffix "-ST" for chassis mounting (ex. AMEL30-12S277HAGY-ST is chassis mounting version).

### Input Specifications

Parameters	Conditions	Typical	Maximum	Units
Input current	115VAC	1.0	--	A
	230VAC	0.5	--	A
	277VAC	0.3	--	A
Inrush current	115VAC	25	--	A
	230VAC	45	--	A
Leakage	277VAC	--	0.25	mA

### Output Specifications

Parameters	Conditions	Typical	Maximum	Units
Voltage accuracy	--	±2	--	%
Line regulation	Full load	±0.5	--	%
Load regulation	5V output	±1	--	%
	Others	±0.5	--	%
Ripple & Noise*	5V output	--	80	mV p-p
	12/15V output	--	120	mV p-p
	24V output	--	150	mV p-p
	48V output	--	240	mV p-p
Hold up time	115VAC	10	--	ms
	230VAC	40	--	ms

\* Ripple and Noise are measured at 20MHz bandwidth with a 47μF electrolytic capacitor and a 0.1μF ceramic capacitor. Please refer to the application note for specific details.

### Isolation Specification

Parameters	Conditions	Typical	Maximum	Units
Tested I/O voltage	60 sec	3000	--	VAC
Resistance	500VDC	>100	--	MΩ

General Specifications				
Parameters	Conditions	Typical	Maximum	Units
Isolation level	II			
Oversoltage category	III			
Over current protection	Hiccup, Auto recovery	≥ 115	160	% of Iout
Over voltage protection	5Vout, shut off o/p voltage, clamping by Zener diode	5.25	7.5	VDC
	12Vout, shut off o/p voltage, clamping by Zener diode	12.8	16	VDC
	15Vout, shut off o/p voltage, clamping by Zener diode	17	24	VDC
	24Vout, shut off o/p voltage, clamping by Zener diode	27	34	VDC
	48Vout, shut off o/p voltage, clamping by Zener diode	50.4	63	VDC
Short circuit protection	Hiccup, Continuous, Auto recovery			
Operating temperature	See derating graph	-30 to +85	--	°C
Storage temperature	--	-40 to +85	--	°C
Wave soldering temperature	Duration 5s max.	265	--	°C
Manual soldering temperature	Duration 3s max.	390	--	°C
No-load power consumption	--	--	0.1	W
Power Derating	+40 °C to +70 °C, 100VAC, 5V	1.67	--	%/°C
	+45 °C to +70 °C, 230VAC, 5V	2	--	%/°C
	+50 °C to +70 °C, 100/230VAC, other models	2.5	--	%/°C
	+70 °C to +85 °C, all models	2	--	%/°C
	85VAC to 100VAC	1.33	--	%/VAC
Temperature coefficient	0~40°C	±0.03	--	%/°C
Cooling	Free air convection			
Humidity	Non-condensing, Storage	10	95	% RH
	Non-condensing, Operating	20	90	% RH
Altitude application	--	--	2000	m
Vibration	PCB mountable models	10 ~ 500Hz, 2G 10min. /1cycle, period for 60min. each along X,Y,Z axes		
	With optional -ST mounting plate	10 ~ 500Hz, 5G 10min. /1cycle, period for 60min. each along X,Y,Z axes		
Weight	PCB mountable models	94	--	g
	With optional -ST mounting plate	113	--	g
Dimensions (L x W x H)	PCB mountable models	2.74 x 1.54 x 0.95 inches (69.60 x 39.00 x 24.20 mm)		
	With optional -ST mounting plate	3.58 x 1.54 x 1.12 inches (91.00 x 39.21 x 28.50mm)		
MTBF	> 654 700 hrs (MIL-HDBK -217F, t=+25°C)			
NOTE: All specifications in this datasheet are measured at an ambient temperature of 25°C, humidity<75%, nominal input voltage and at rated output load unless otherwise specified.				

Safety Specifications		
Parameters		
Agency approvals	UL62368-1	
Standards	Information technology Equipment	Designed to meet IEC/EN62368-1, EN60335-1, EN62233
	EMI - Conducted and radiated emission	EN55014-1, class B
	Limits for Harmonic current emissions	EN 61000-3-2, class A
	Voltage fluctuations and flicker	EN 61000-3-3
	Electrostatic Discharge Immunity	EN 61000-4-2, Level 2 contact ±4KV, Level 3 Air ±8KV, Criteria A
	RF, Electromagnetic Field Immunity	EN 61000-4-3, Level 3, Criteria A
	Electrical Fast Transient/Burst Immunity	EN 61000-4-4, Level 3, Criteria B
	Surge Immunity	EN 61000-4-5, Level 3 ±1KV/L-N, Criteria B
	RF, Conducted Disturbance Immunity	EN 61000-4-6, Level 3, Criteria A
Magnetic field immunity	EN 61000-4-8, Level 4, Criteria A	

Voltage Dips and interruptions

EN 61000-4-11, >95% dip 0.5 periods, 30% dip 25 periods, >95% interruptions 250 periods

## Derating

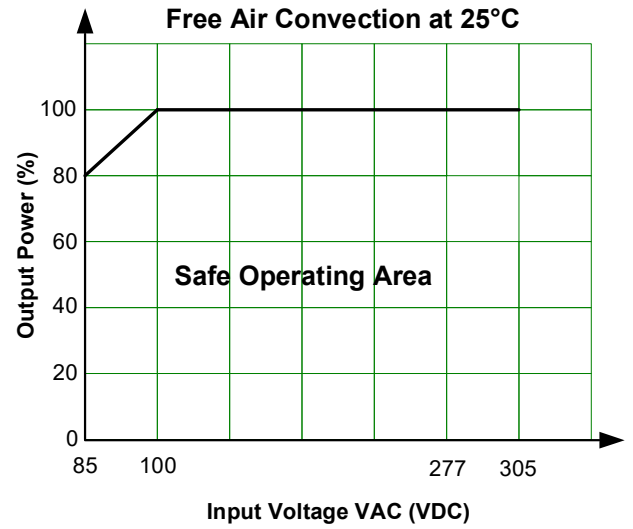
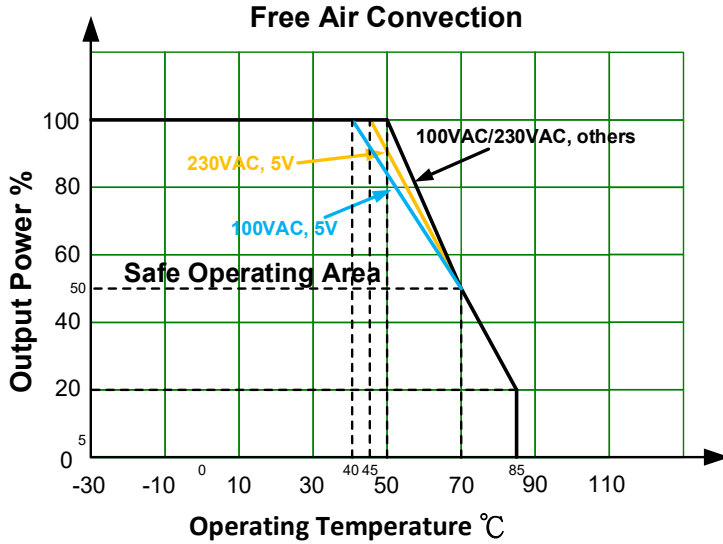

## Dimensions

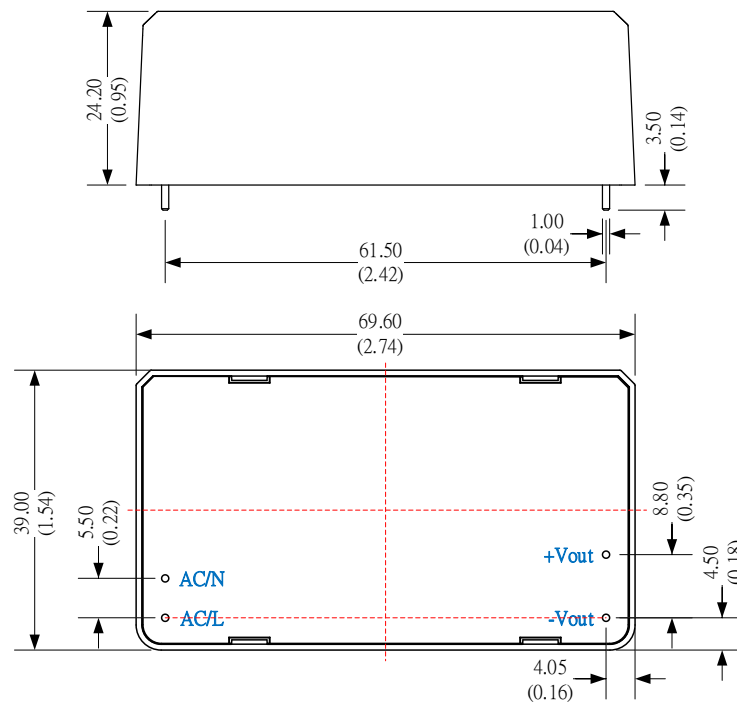

Unit: mm(inch)  
General tolerance:  $\pm 0.50(\pm 0.02)$

**Dimensions with Optional - ST**

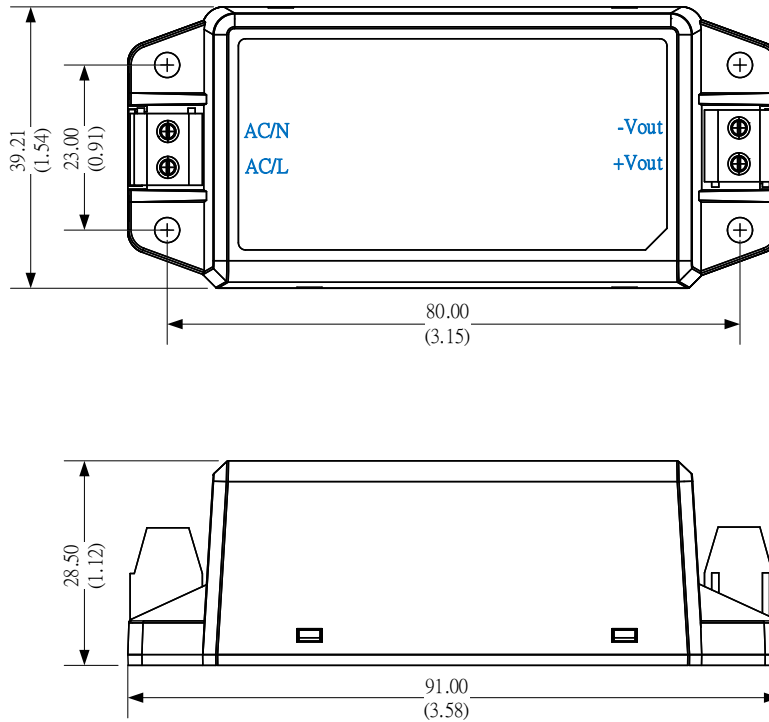

Unit: mm(inch)  
General tolerance:  $\pm 0.50(\pm 0.02)$

**NOTE:** 1. Datasheets are updated as needed and as such, specifications are subject to change without notice. Once printed or downloaded, datasheets are no longer controlled by Aimtec; refer to [www.aimtec.com](http://www.aimtec.com) for the most current product specifications. 2. Product labels shown, including safety agency certifications on labels, may vary based on the date manufactured. 3. Mechanical drawings and specifications are for reference only. 4. All specifications are measured at an ambient temperature of 25°C, humidity<75%, nominal input voltage and at rated output load unless otherwise specified. 5. Aimtec may not have conducted destructive testing or chemical analysis on all internal components and chemicals at the time of publishing this document. CAS numbers and other limited information are considered proprietary and may not be available for release. 6. This product is not designed for use in critical life support systems, equipment used in hazardous environments, nuclear control systems or other such applications which necessitate specific safety and regulatory standards other the ones listed in this datasheet. 7. Warranty is in accordance with Aimtec's standard Terms of Sale available at [www.aimtec.com](http://www.aimtec.com).