

AM2DM-MZ

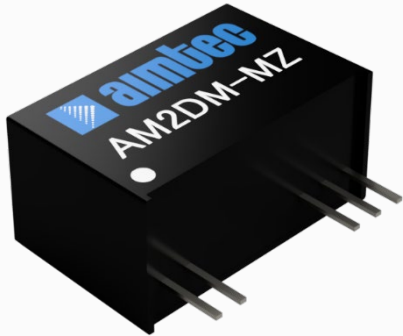

SIP9 Package

Aimtec launched the AM2DM-MZ, a 2W medical grade DC/DC converter in a SIP9 case to satisfy the rigorous power demands of medical equipment. This series meets EN60601-1, ANSI/AAMI ES60601-1 medical safety standard and has a high I/O isolation of 5000VAC or 6000VDC with reinforced insulation rated for a 250VAC working voltage and 2xMOPP.

This 2W converter has a standard input voltage range of 10.8-26.4VDC, single & dual outputs (5...24V, +/-5...+/-15V). This new series offers great operating temperatures, from -40 to 105°C with full power up to 85°C, as well as a great 19,360,000h MTBF come standard. In terms of safety, this series has output short circuit protections.

AM2DM-MZ series meet reinforced insulation requirements. They are specially designed for applications where require compact size, high isolation, low isolation capacitor and low leakage current power. They are widely used in medical, electricity, IGBT driver and so on.

Features

- High I/O Isolation of 5000VAC or 6000VDC
- Continuous Short circuit protection
- Operating Temp: -40 °C to +105 °C
- Industry standard SIP9 pin-out
- Efficiency up to 84%
- Unregulated output
- Meets EN60601-1, ANSI/AAMI ES60601-1 medical safety standard (2xMOPP)



Summary

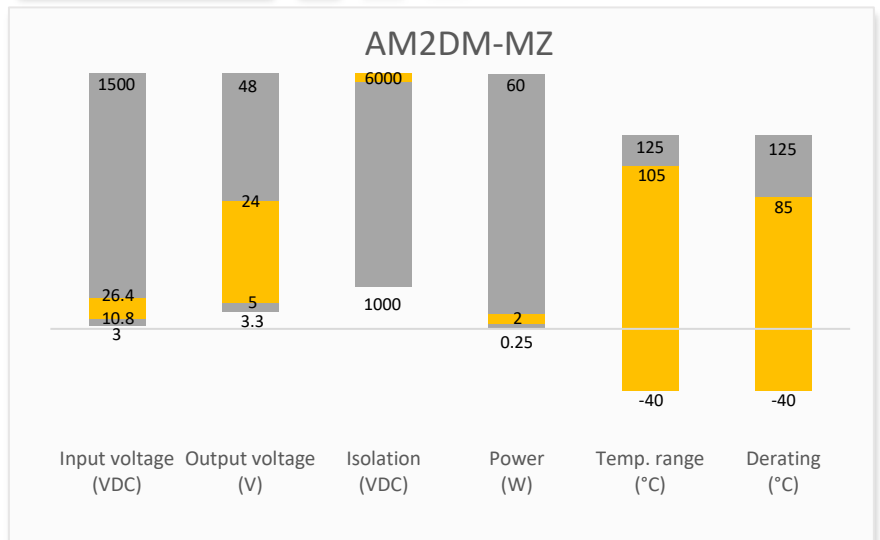

Training



Product Training Video
(click to open)



Press Release

Coming Soon!

Application Notes

Applications



Industrial



Portable Equipment



Medical



IoT

Models & Specifications



Single Output

Model	Input Voltage (VDC)	Output Voltage (VDC)	Input Current Full No load typ. (mA)	Output Current max min (mA)*	Isolation (VDC)	Maximum capacitive Load (μF)	Efficiency Typ. (%)
AM2DM-1205SH60MZ	12 (10.8-13.2)	5	210 / 15	400 / 40	6000	1000	80
AM2DM-1209SH60MZ	12 (10.8-13.2)	9	210 / 15	222 / 22	6000	680	82
AM2DM-1212SH60MZ	12 (10.8-13.2)	12	210 / 15	167 / 17	6000	470	84
AM2DM-1215SH60MZ	12 (10.8-13.2)	15	210 / 15	133 / 14	6000	470	84
AM2DM-1505SH60MZ	15 (13.5-16.5)	5	167 / 15	400 / 40	6000	1000	80
AM2DM-1515SH60MZ	15 (13.5-16.5)	15	167 / 15	133 / 14	6000	470	83
AM2DM-2405SH60MZ	24 (21.6-26.4)	5	106 / 15	400 / 40	6000	2200	79
AM2DM-2409SH60MZ	24 (21.6-26.4)	9	106 / 15	222 / 22	6000	680	81
AM2DM-2412SH60MZ	24 (21.6-26.4)	12	106 / 15	167 / 17	6000	470	82
AM2DM-2415SH60MZ	24 (21.6-26.4)	15	106 / 15	133 / 14	6000	470	84
AM2DM-2424SH60MZ	24 (21.6-26.4)	24	106 / 15	83 / 9	6000	220	84

* Performance will be degraded if the load is not within the output current range.

Dual Output

Model	Input Voltage (VDC)	Output Voltage (VDC)	Input Current Full No load typ. (mA)	Output Current max min (mA)*	Isolation (VDC)	Maximum capacitive Load (μF)	Efficiency Typ. (%)
AM2DM-1205DH60MZ	12 (10.8-13.2)	± 5	210 / 15	± 200 / ± 20	6000	± 1000	80
AM2DM-1209DH60MZ	12 (10.8-13.2)	± 9	210 / 15	± 111 / ± 11	6000	± 470	82
AM2DM-1212DH60MZ	12 (10.8-13.2)	± 12	210 / 15	± 83 / ± 9	6000	± 220	83
AM2DM-1215DH60MZ	12 (10.8-13.2)	± 15	210 / 15	± 67 / ± 7	6000	± 220	84
AM2DM-1505DH60MZ	15 (13.5-16.5)	± 5	167 / 15	± 200 / ± 20	6000	± 1000	78
AM2DM-1509DH60MZ	15 (13.5-16.5)	± 9	167 / 15	± 111 / ± 11	6000	± 470	80
AM2DM-1515DH60MZ	15 (13.5-16.5)	± 15	167 / 15	± 67 / ± 7	6000	± 220	80
AM2DM-2405DH60MZ	24 (21.6-26.4)	± 5	106 / 15	± 200 / ± 20	6000	± 1000	79
AM2DM-2409DH60MZ	24 (21.6-26.4)	± 9	106 / 15	± 111 / ± 11	6000	± 470	81
AM2DM-2412DH60MZ	24 (21.6-26.4)	± 12	106 / 15	± 83 / ± 9	6000	± 220	82
AM2DM-2415DH60MZ	24 (21.6-26.4)	± 15	106 / 15	± 67 / ± 7	6000	± 220	81

* Performance will be degraded if the load is not within the output current range.

Input Specification

Parameters	Conditions	Typical	Maximum	Units
Filter	Capacitor			
Absolute maximum rating	Maximum duration 1s, 12Vin	> -0.7	18	VDC
	Maximum duration 1s, 15Vin	> -0.7	21	VDC
	Maximum duration 1s, 24Vin	> -0.7	30	VDC
Input reflected ripple current		200		mA

Output Specification

Parameters	Conditions	Typical	Maximum	Units
Voltage accuracy	See output voltage tolerance	5	10	%
Line regulation	Per 1% Vin change		1.2	
Load regulation	10-100% load, 5Vout models		20	%
	10-100% load, other models		15	%
Ripple & Noise*	5Vout models	100	150	mV p-p
	other models	80	120	mV p-p
Temperature coefficient	Full load	±0.02		%/°C

* Ripple and Noise are measured at 20MHz bandwidth. Please refer to the application note for specific details.

Isolation Specification				
Parameters	Conditions	Typical	Maximum	Units
Tested I/O voltage	60 sec, leakage ≤ 1mA	>5000		VAC
	60 sec, leakage ≤ 1mA	>6000		VDC
Tested I/O resistance	500VDC	>1000		MΩ
Capacitance	100kHz/0.1V	4		pF
Leakage Current	250VAC, 50/60Hz		2	μA

General Specifications				
Parameters	Conditions	Typical	Maximum	Units
Switching frequency	Full load, nominal input	200		KHz
Short circuit protection	Continuous, Auto recovery			
Operating temperature	With derating	-40 to +105		°C
Storage temperature		-55 to +125		°C
Case temperature rise	Ta = 25°C	25		°C
Manual soldering temperature	1.5mm away from case, duration ≤ 10sec		300	°C
Cooling	Free air convection			
Humidity	Non-condensing	>5	95	% RH
Creepage & Clearance distance		>8		mm
Altitude			5000	m
Case material	Black plastic (flammability to UL 94V-0)			
Weight		4.0		g
Dimensions (L x W x H)	0.77 x 0.39 x 0.49 inches (19.50 x 9.80 x 12.50 mm)			
MTBF	19 360 000 hrs (MIL-HDBK -217F, t=+25°C) / Full Load			

NOTE: All specifications in this datasheet are measured at an ambient temperature of 25°C, humidity<75%, nominal input voltage and at rated output load unless otherwise specified.

Safety Specifications			
Parameters			
Standards	Designed to meet UL61010-1		
	Information technology equipment	Design to meet IEC62368, EN60601-1, ANSI/AAMI ES60601-1(2xMOPP)	
	EMC - Conducted and radiated emission	CISPR32 / EN55032, class A with the recommended EMI circuit (Only for 15V,24V input/Dual output models)	
		CISPR32 / EN55032, class B with the recommended EMI circuit (Other models) EN60601-1-2/CISPR 11 GROUP1, class A with the recommended EMI circuit (Only for 15V,24V input/Dual output models) EN60601-1-2/CISPR 11 GROUP1, class B with the recommended EMI circuit (Other models)	
Electrostatic Discharge Immunity	EN60601-1-2(IEC/EN61000-4-2) Air ±15KV, Contact ±8KV, Criteria B		

Derating

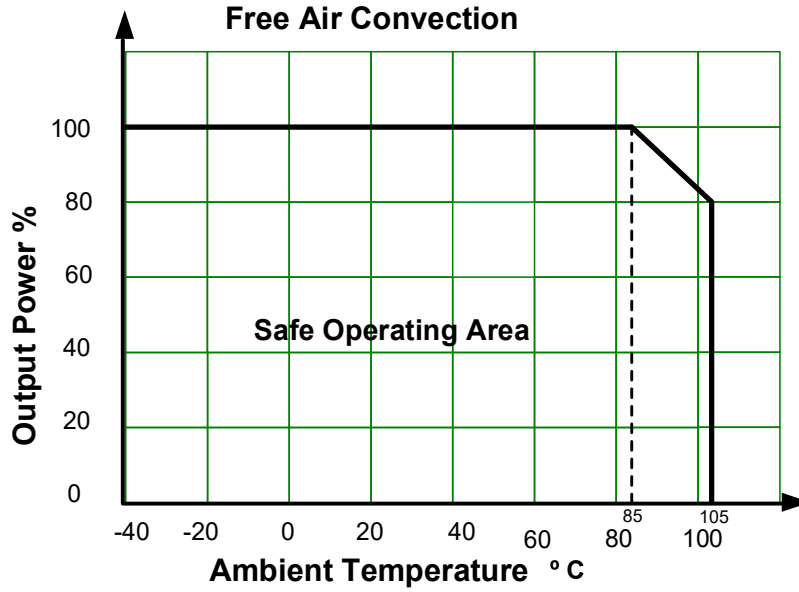

Output voltage tolerance



5Vout models

Tolerance Envelope Graph

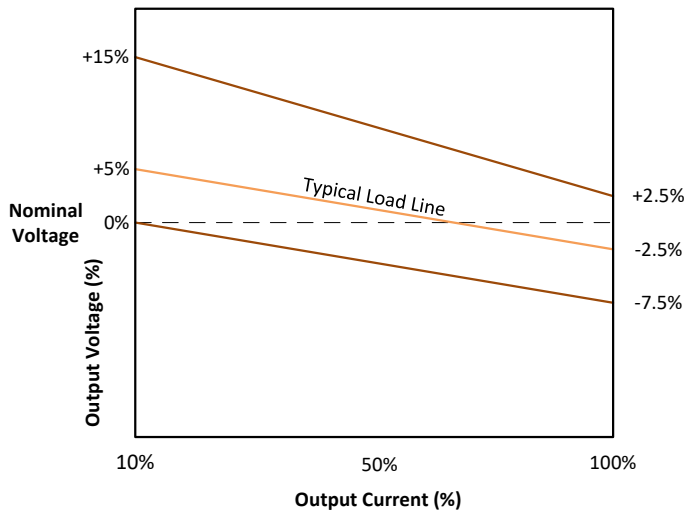

Other models

Tolerance Envelope Graph

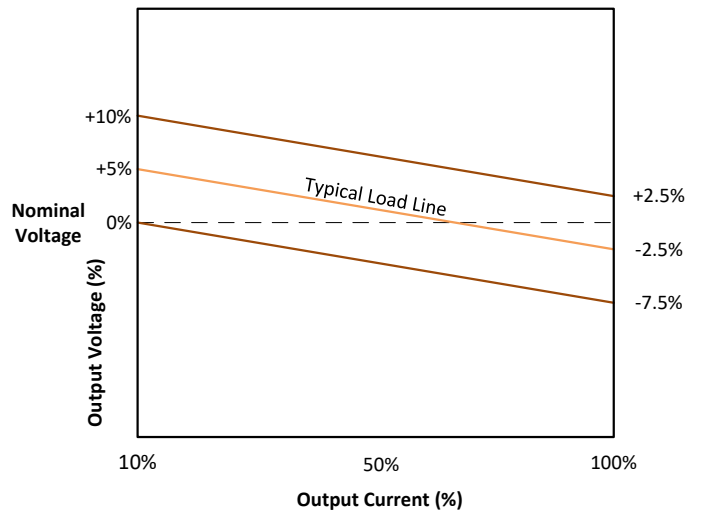

Typical application circuit

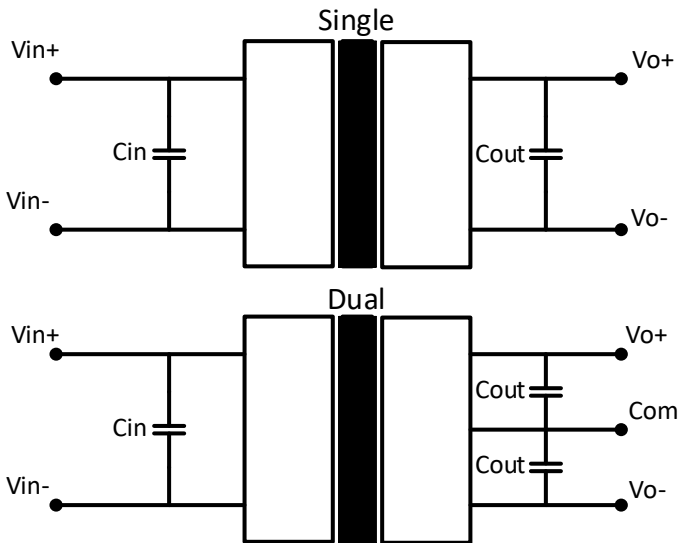

Vin	Cin
12V	10 μ F/25V
15V	4.7 μ F/25V
24V	2.2 μ F/50V

	Vout	Cout
Single	5 / 9V	10 μ F/16V
	12V	2.2 μ F/25V
	15V	1 μ F/25V
	24V	0.47 μ F/50V
Dual	$\pm 5 / \pm 9V$	4.7 μ F/16V
	$\pm 12 / \pm 15V$	1 μ F/25V

Recommended EMI circuit



15/24 Vin, Dual output models

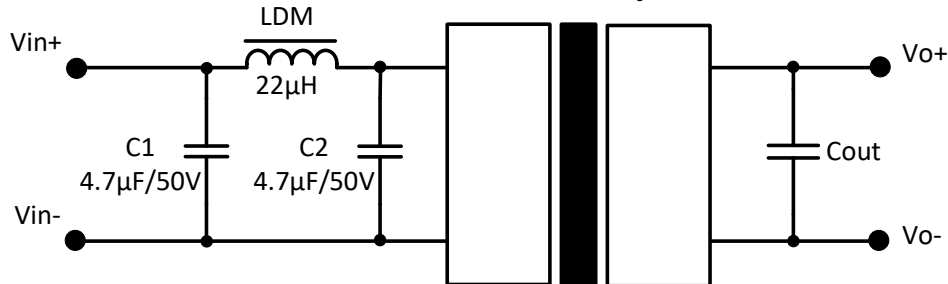

12/15/24 Vin models

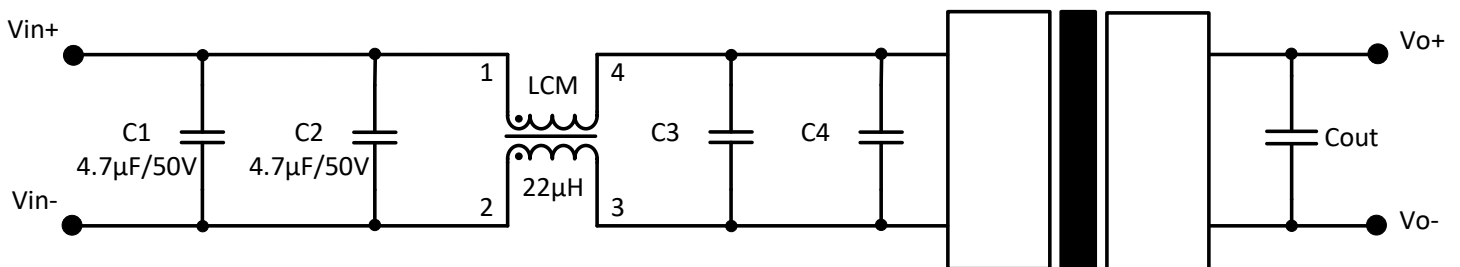

12/15/24Vin models			
Vout models	C3	C4	LCM
AM2DM-2424SH60MZ	100 μ F/50V	--	22 μ H (Nickel zinc inductance)
Others	4.7 μ F/50V	4.7 μ F/50V	22 μ H (Nickel zinc inductance)

Dimensions

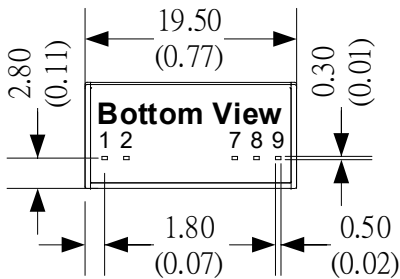
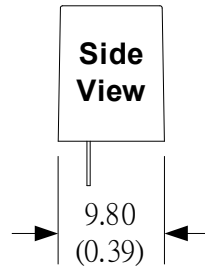
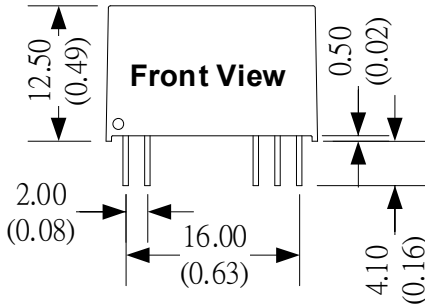

Dimensions mm (inch)
General Tolerance ± 0.50 (± 0.02)
Pin Diameter ± 0.10 (± 0.004)

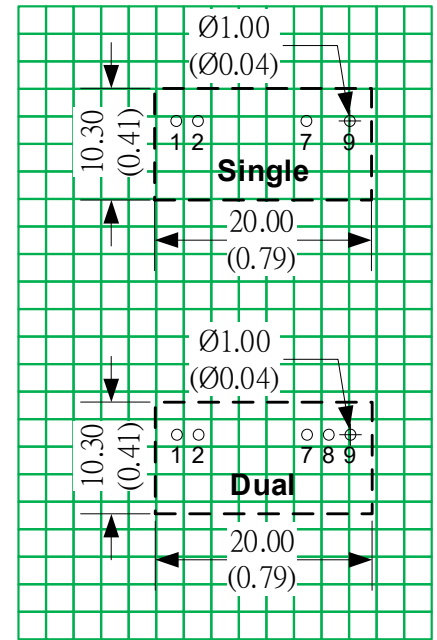

Grid 2.54*2.54mm

Pin Out Specifications		
Pin	Single output	Dual output
1	+V Input	+V Input
2	-V Input	-V Input
7	-V Output	-V Output
8	No Pin	Common
9	+V Output	+V Output

NOTE: 1. Datasheets are updated as needed and as such, specifications are subject to change without notice. Once printed or downloaded, datasheets are no longer controlled by Aimtec; refer to www.aimtec.com for the most current product specifications. **2.** Product labels shown, including safety agency certifications on labels, may vary based on the date manufactured. **3.** Mechanical drawings and specifications are for reference only. **4.** All specifications are measured at an ambient temperature of 25°C, humidity<75%, nominal input voltage and at rated output load unless otherwise specified. **5.** Aimtec may not have conducted destructive testing or chemical analysis on all internal components and chemicals at the time of publishing this document. CAS numbers and other limited information are considered proprietary and may not be available for release. **6.** This product is not designed for use in critical life support systems, equipment used in hazardous environments, nuclear control systems or other such applications which necessitate specific safety and regulatory standards other the ones listed in this datasheet. **7.** Warranty is in accordance with Aimtec's standard Terms of Sale available at www.aimtec.com.