



FEATURES:

- Wide input voltage range (2:1)
- Efficiency up to 88%
- Isolation voltage of 1500VDC
- Input under voltage lockout
- Operating temperature: -40 °C to +85 °C
- No load consumption $\leq 0.12W$
- Continuous Short Circuit Protection
- Over Current, Over Voltage Protection



Models
Single output

Model	Input Voltage (V)	Output Voltage (V)	Output Current max (mA)	Isolation (VDC)	Max Capacitive Load(μ F)	Efficiency (%)
AM6C-1205S-NZ	9-18	5	1200	1500	1000	81
AM6C-1212S-NZ	9-18	12	500	1500	470	85
AM6C-2403S-NZ	18-36	3.3	1500	1500	1800	77
AM6C-2405S-NZ	18-36	5	1200	1500	1000	82
AM6C-2412S-NZ	18-36	12	500	1500	470	85
AM6C-2415S-NZ	18-36	15	400	1500	220	86
AM6C-2424S-NZ	18-36	24	250	1500	100	87

Models
Dual output

Model	Input Voltage (V)	Output Voltage (V)	Output Current max (mA)	Isolation (VDC)	Max Capacitive Load(μ F)	Efficiency (%)
AM6C-1205D-NZ‡	9-18	± 5	± 600	1500	470	81
AM6C-1212D-NZ‡	9-18	± 12	± 250	1500	100	85
AM6C-2405D-NZ‡	18-36	± 5	± 600	1500	470	83
AM6C-2412D-NZ‡	18-36	± 12	± 250	1500	100	87
AM6C-2415D-NZ‡	18-36	± 15	± 200	1500	100	87

Only the model AM6C-2405S-NZ can add suffix “-ST” for optional screw terminal bottom plate or “-STD” for optional DIN Rail screw terminal bottom plate and reverse voltage protection. The optional package will be EOL by 30 Dec, 2020.

*‡ - Reference the Safety table

NOTE: All specifications in this datasheet are measured at an ambient temperature of 25°C, humidity<75%, nominal input voltage and at rated output load unless otherwise specified.

Input Specifications

Parameters	Nominal	Typical	Maximum	Units
Voltage range	12	9-18		VDC
	24	18-36		
Filter	π (Pi) Network			
Input under-voltage lockout	12		5.5 - 6.5	VDC
	24		14 - 15.5	
Absolute Maximum Rating	12		-0.7 - 25	VDC
	24		-0.7 - 50	
Peak Input Voltage time			1	s
No Load Input Current	12		25	mA
	24		15	
Input reflected current		20		mA

Isolation Specifications

Parameters	Conditions	Typical	Rated	Units
Tested I/O voltage	1 min, $\leq 1mA$		1500	VDC
Resistance	Isolation 500VDC	>1000		MOhm
Capacitance	100kHz, 0.1V	1000		pF

Output Specifications

Parameters	Conditions	Typical	Maximum	Units
Voltage accuracy		±2	±3	%
Voltage balance (Dual Output Models)	Balanced Load	±1.5		%
Cross Regulation (Dual Output Models)	50% load on one output – 10% to 100% load on second load		±5	%
Over voltage protection		110-160		% of Vout
Short Circuit protection	Continuous, Auto recovery			
Over current protection		110-190		% of Iout
Line voltage regulation	LL-HL, full load	±1		% of Vin
Load voltage regulation	5% -100% load	±1.5		%
Temperature coefficient	Full load	±0.03		%/°C
Ripple & Noise	20MHz Bandwidth	75		mV p-p
Transient recovery time	25% load step change	500		µs
Transient recovery deviation	25% load step change	±5	±8	%

General Specifications

Parameters	Conditions	Typical	Maximum	Units
Switching frequency	100% load	300		KHz
Operating temperature	With derating above 71°C	-40 to +85		°C
Storage temperature		-55 to +125		°C
Maximum case temperature			105	°C
Cooling	Free convection			
Humidity			95	% RH
Case material	Aluminum alloy			
Weight	Pin mountable	14		g
	-ST option	36		
	-STD option	56		
Dimensions (L x W x H)	Aluminum case	1 x 1 x 0.46 inches	25.40 x 25.40 x 11.70 mm	
	Optional packages	See dimensions drawing		
MTBF	>1,000,000 hours (MIL-HDBK -217F, Ground Benign, t=+25°C)			
Maximum soldering temperature	10sec, 1.5mm from case		300	°C

Environmental Specifications

Parameters		
Vibration	Test mode	10-55Hz
	Acceleration	10G, 30min one cycle, every axis tested

Safety Specifications

Parameters		
Standards	Information Technology Equipment	Designed to meet UL60950-1 (models marked with †), EN55022 Class B, with the recommended circuit below, EN55024
	Electrostatic Discharge Immunity	IEC 61000-4-2, Contact ±4KV, Criteria B
	RF, Electromagnetic Field Immunity	IEC 61000-4-3, 10V/m, Criteria A
	Electrical Fast Transient / Burst Immunity	IEC 61000-4-4, ±2KV, Criteria B, with the recommended circuit below
	Surge Immunity	IEC 61000-4-5, ±2KV, Criteria B, with the recommended circuit below
	RF, Conducted Disturbance Immunity	IEC 61000-4-6, 3 Vrms, Criteria A
	Voltage dips, Short interruptions and Voltage Variations Immunity	IEC61000-4-29, 0-70%, Criteria B

Dimensions

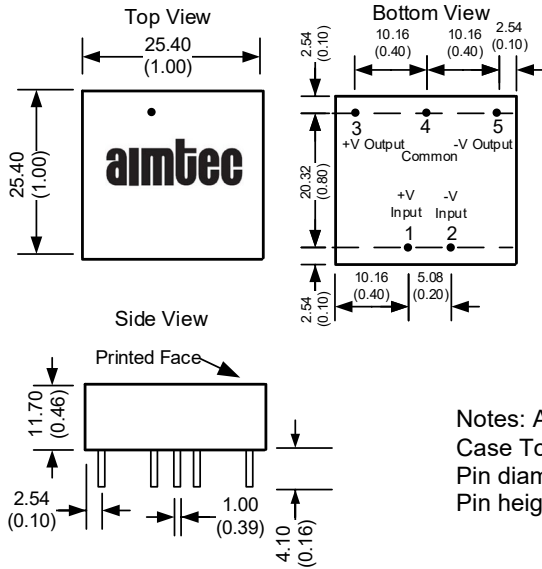

Notes: All dimensions are typical in millimeters (inches).
Case Tolerance ± 0.25 (± 0.01)
Pin diameter tolerance ± 0.1 (± 0.004)
Pin height tolerance ± 0.5 (± 0.02)

Pin Out Specifications

Pin	Single	Dual
1	+V Input	+V Input
2	-V Input	-V Input
3	+V Output	+V Output
4	No pin	Common
5	-V Output	-V Output

Dimensions with -ST options

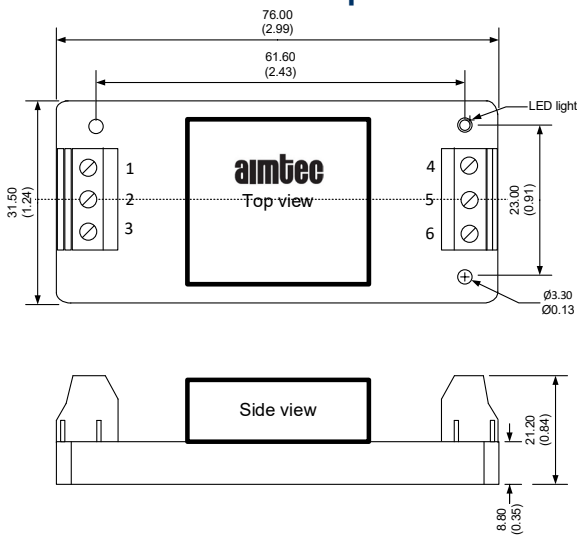

Pin Out Specifications

Pin	Single	Dual
1	No Connection	No Connection
2	-V Input	-V Input
3	+V Input	+V Input
4	-V Output	-V Output
5	No Connection	Common
6	+V Output	+V Output

Dimensions: mm (inch)
Case Tolerance: ± 0.50 (0.02)
Wire gauge: 24-12AWG
Torque Tightening: Max 0.4N*m

Dimensions with -STD options

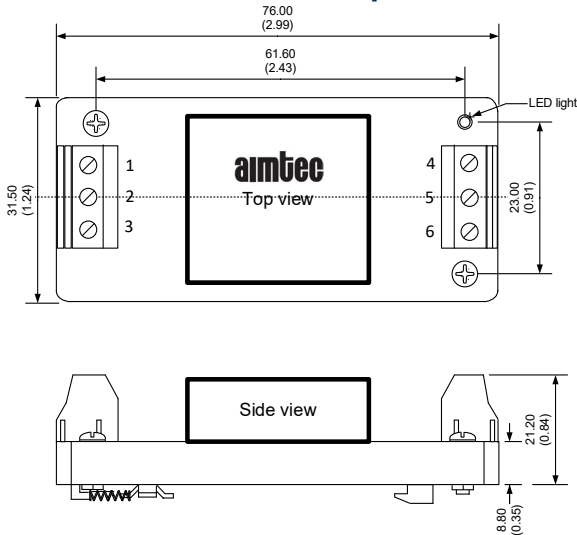

Pin	Single	Dual
1	No Connection	No Connection
2	-V Input	-V Input
3	+V Input	+V Input
4	-V Output	-V Output
5	No Connection	Common
6	+V Output	+V Output

Dimensions: mm (inch)
Case Tolerance: ± 0.50 (0.02)
Wire gauge: 24-12AWG
Mounting Rail: TS35
Torque Tightening: Max 0.4N*m

Derating

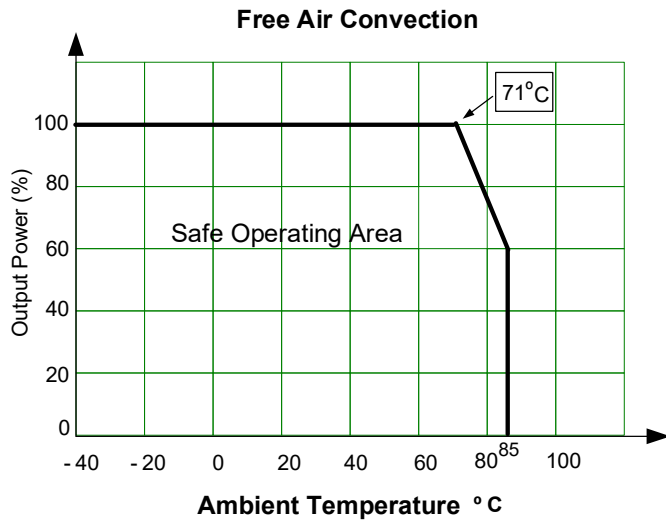

EMC recommended circuit

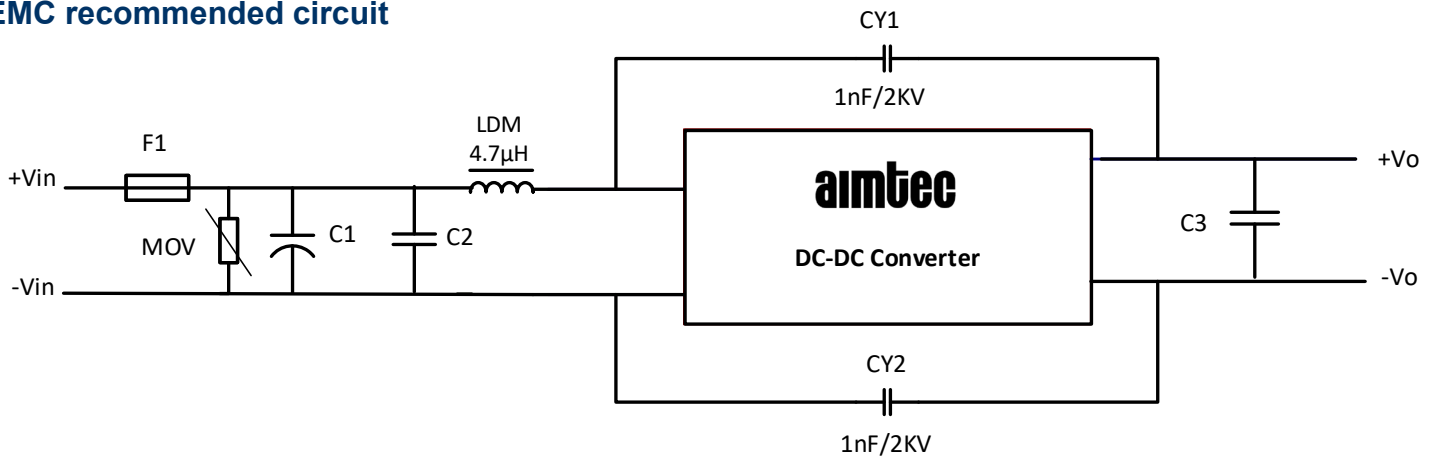

	12V input	24V input	48V input
MOV	S14K20	S20K30	S14K60
C1	1000µF/35V	1000µF/50V	330µF/100V
C2	1µF/50V		1µF/100V
C3	10µF/50V		10µF/100V

NOTE: 1. Datasheets are updated as needed and as such, specifications are subject to change without notice. Once printed or downloaded, datasheets are no longer controlled by Aimtec; refer to www.aimtec.com for the most current product specifications. 2. Product labels shown, including safety agency certifications on labels, may vary based on the date manufactured. 3. Mechanical drawings and specifications are for reference only. 4. All specifications are measured at an ambient temperature of 25°C, humidity<75%, nominal input voltage and at rated output load unless otherwise specified. 5. Aimtec may not have conducted destructive testing or chemical analysis on all internal components and chemicals at the time of publishing this document. CAS numbers and other limited information are considered proprietary and may not be available for release. 6. This product is not designed for use in critical life support systems, equipment used in hazardous environments, nuclear control systems or other such applications which necessitate specific safety and regulatory standards other the ones listed in this datasheet. 7. Warranty is in accordance with Aimtec's standard Terms of Sale available at www.aimtec.com.