



### FEATURES:

- Wide 4:1 Input Voltage Range
- High efficiency up to 90%
- 1500 VDC Isolation
- Over Current Protection
- No load consumption  $\leq 0.12W$
- Operating Temperature  $-40^{\circ}C$  to  $+85^{\circ}C$
- Output Over Voltage protection
- Continuous Short Circuit Protection
- Input Under Voltage Protection
- Remote On/Off control

## Models

### Single output



Model	Input Voltage (V)	Output Voltage (V)	Output Current max (A)	Isolation (VDC)	Max Capacitive Load ( $\mu F$ )	Efficiency Typ. (%)
AM20CW-2403S-NZ	9-36	3.3	5	1500	10000	88
AM20CW-2405S-NZ	9-36	5	4	1500	10000	90
AM20CW-2412S-NZ	9-36	12	1.667	1500	1600	90
AM20CW-2415S-NZ	9-36	15	1.333	1500	1000	89
AM20CW-2424S-NZ	9-36	24	0.833	1500	500	91
AM20CW-4803S-NZ	18-75	3.3	5	1500	10000	88
AM20CW-4805S-NZ	18-75	5	4	1500	10000	90
AM20CW-4812S-NZ	18-75	12	1.667	1500	1600	91
AM20CW-4815S-NZ	18-75	15	1.333	1500	1000	91
AM20CW-4824S-NZ	18-75	24	0.833	1500	500	91

Add suffix “-ST” for optional screw terminal bottom plate or “-STD” for optional DIN Rail screw terminal bottom plate and reverse voltage protection. (Single output models only)

\*Add suffix “-K” for optional heatsink. (Single output models only)

## Models

### Dual output

Model	Input Voltage (V)	Output Voltage (V)	Output Current max (A)	Isolation (VDC)	Max Capacitive Load ( $\mu F$ )	Efficiency Typ. (%)
AM20CW-2405D-NZ	9-36	$\pm 5$	$\pm 2$	1500	2000	87
AM20CW-2412D-NZ	9-36	$\pm 12$	$\pm 0.833$	1500	800	90
AM20CW-2415D-NZ	9-36	$\pm 15$	$\pm 0.667$	1500	600	90
AM20CW-2424D-NZ	9-36	$\pm 24$	$\pm 0.417$	1500	300	89
AM20CW-4805D-NZ	18-75	$\pm 5$	$\pm 2$	1500	2000	86
AM20CW-4812D-NZ	18-75	$\pm 12$	$\pm 0.833$	1500	800	90
AM20CW-4815D-NZ	18-75	$\pm 15$	$\pm 0.667$	1500	600	90
AM20CW-4824D-NZ	18-75	$\pm 24$	$\pm 0.417$	1500	300	90

NOTE: All specifications in this datasheet are measured at an ambient temperature of  $25^{\circ}C$ , humidity  $< 75\%$ , nominal input voltage and at rated output load unless otherwise specified.

## Input Specifications

Parameters	Nominal	Typical	Maximum	Units	
Voltage range	24 Vin 48 Vin	9-36 18-75		VDC	
Filter	Pi network				
Absolute Maximum Rating (100ms)	24 Vin 48 Vin		-0.7 - 50 -0.7 - 100	VDC	
No Load Input Current	24 Vin	3.3V single output	30	50	mA
		5V single output	35	55	
		12V single output	6	15	
		15V single output	6	15	
		24V single output	10	20	
		All dual output	10	20	

	48 Vin	3.3V single output	15	30	mA
		5V single output	20	30	
		12V single output	3	15	
		15V single output	3	15	
		24V single output	4	15	
		All dual output	5	11	
Input reflected current			30		mA
Input Under voltage turn off	24 Vin		5.5 ~ 6.5		VDC
	48 Vin		12 ~ 15.5		
Startup voltage	24 Vin			9	VDC
	48 Vin			18	
Startup time	Nominal input, resistive load		10		ms
Remote On/Off Control		On Off	3.5-12VDC or leave open 0-1.2VDC or connect to GND, idle current 2-7mA		

### Isolation Specifications

Parameters	Conditions	Typical	Maximum	Units
Tested I/O voltage	60 sec, <1mA	>1500		VDC
Resistance	500VDC	>1000		MOhm
Capacitance	I/O, 100KHz/0.1V	2000		pF

### Output Specifications

Parameters	Conditions	Typical	Maximum	Units	
Voltage accuracy	Single output 0% to 100% load	±1	±3	%	
	Dual output 5%-100% load	±1	±3		
Over voltage protection		110-160		% of Vout	
Over current protection		150		% of Iout	
Short circuit protection	Continuous				
Short circuit restart	Auto-Recovery				
Line voltage regulation	Single output, Full load, LL to HL	±0.2	±0.5	% of Vin	
	Dual output, Full load, LL to HL	1 <sup>st</sup> output	±0.2		±0.5
		2 <sup>nd</sup> output	±0.4		±1
Load voltage regulation	5% to 100% load	±0.5	±1	%	
Cross regulation	50% at 1st output, 10-100% at 2nd output		±5	%	
Voltage adjustment	Single output		±10	%Vout	
Temperature coefficient	100% load		±0.03	%/°C	
Ripple & Noise	Single output, 20MHz, 5-100% load	50	100	mV p-p	
	Dual output, 20MHz, 5-100% load	100	200		
Transient recovery time	25% load step change	300	500	µs	
Transient recovery deviation	3.3/5VDC single output, 25% load step change	±5	±8	%	
	±5VDC dual output, 25% load step change	±3	±8		
	Others, 25% load step change	±3	±5		

### General Specifications

Parameters	Conditions	Typical	Maximum	Units
Switching frequency	3.3/5VDC single output, 100% load	300		KHz
	Others, 100% load	270		
Operating temperature	3.3/5VDC single output with derating curve	-40 to +95		°C
	Others with derating curve	-40 to +105		
Storage temperature		-55 to +125		°C
Maximum case temperature			105	°C
Cooling	Free air convection			
Humidity			95	% RH
Case material	Aluminum Alloy			
Weight	Pin mountable without heatsink		15	g
	Pin mountable with heatsink		20	
	-ST option without heatsink		38	
	-ST option with heatsink		40	
	-STD option without heatsink		58	
	-STD option with heatsink		60	

Dimensions (L x W x H)	Pin mountable without heatsink	1.00 x 1.00 x 0.46 inches	25.40 x 25.40 x 11.70 mm
	Pin mountable with heatsink	1.00 x 1.00 x 0.64 inches	25.40 x 25.40 x 16.20 mm
	-ST option without heatsink	2.99 x 1.24 x 0.83 inches	76.00 x 31.50 x 21.20 mm
	-ST option with heatsink	2.99 x 1.24 x 0.99 inches	76.00 x 31.50 x 25.20 mm
	-STD option without heatsink	2.99 x 1.24 x 1.02 inches	76.00 x 31.50 x 25.80 mm
	-STD option with heatsink	2.99 x 1.24 x 1.17 inches	76.00 x 31.50 x 29.80 mm
MTBF	>1,000,000 hours (MIL-HDBK -217F, Ground Benign, t=+25°C)		
Maximum soldering temperature	1.5mm from case for 10 sec	300	°C

## Environmental Specifications

### Parameters

Vibration	Test mode	10-150Hz
	Acceleration	5G, every axis tested

## Safety Specifications

### Parameters

Approval	CE	
Standards	Information technology Equipment	IEC/EN62368-1, Designed to meet UL 62368-1 (with exception of the dual output models)
	EMI - Conducted and radiated emission	EN 55032, class B (with the recommended EMC circuit)
	Electrostatic Discharge Immunity	IEC 61000-4-2, Contact ±4KV, Criteria B
	RF, Electromagnetic Field Immunity	IEC 61000-4-3, 10V/m, Criteria A
	Electrical Fast Transient / Burst Immunity	IEC 61000-4-4, ±2KV, Criteria B (with the recommended EMC circuit)
	Surge Immunity	IEC 61000-4-5, ±2KV, Criteria B (with the recommended EMC circuit)
	RF, Conducted Disturbance Immunity	IEC 61000-4-6, 3 Vrms, Criteria A

## Pin Out Specifications

Pin	Single
1	+V Input
2	-V Input
3	On/Off Control
4	+V Output
5	Trim
6	-V Output

Pin	Dual
1	+V Input
2	-V Input
3	On/Off Control
4	+V Output
5	Common
6	-V Output

## Dimensions

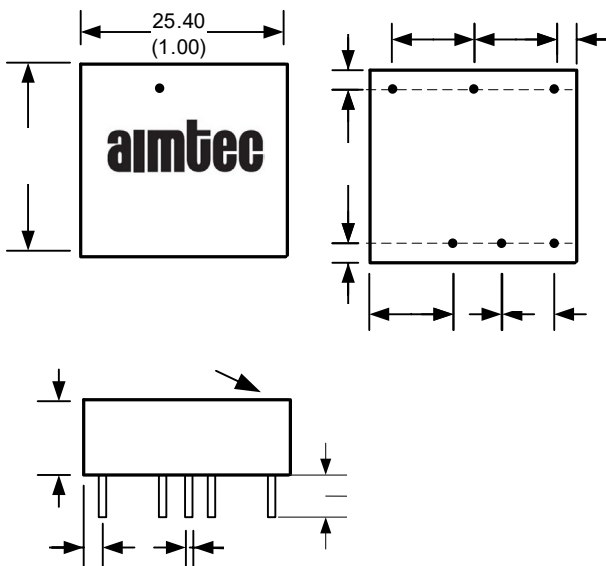

**Heatsink Option: AM20CW-NZ-K**

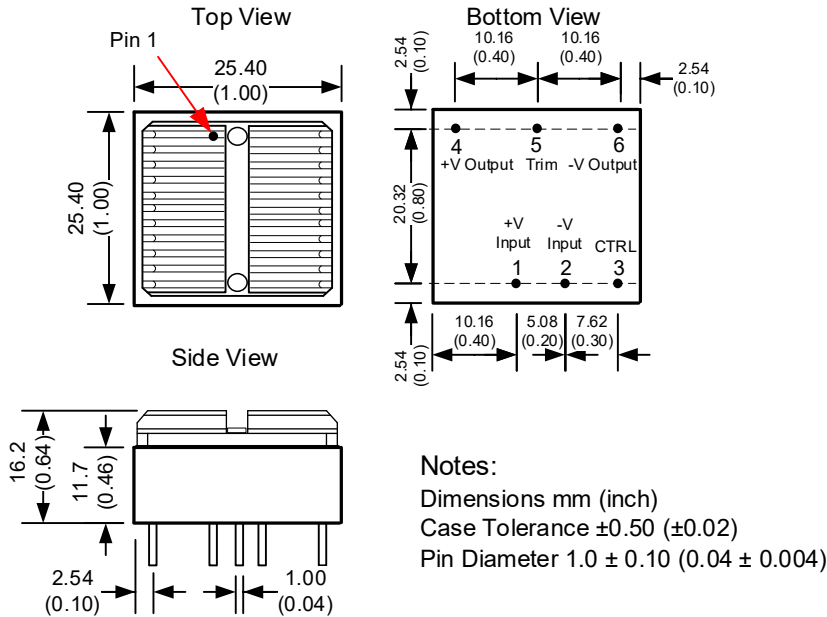

**Dimensions with -ST options**

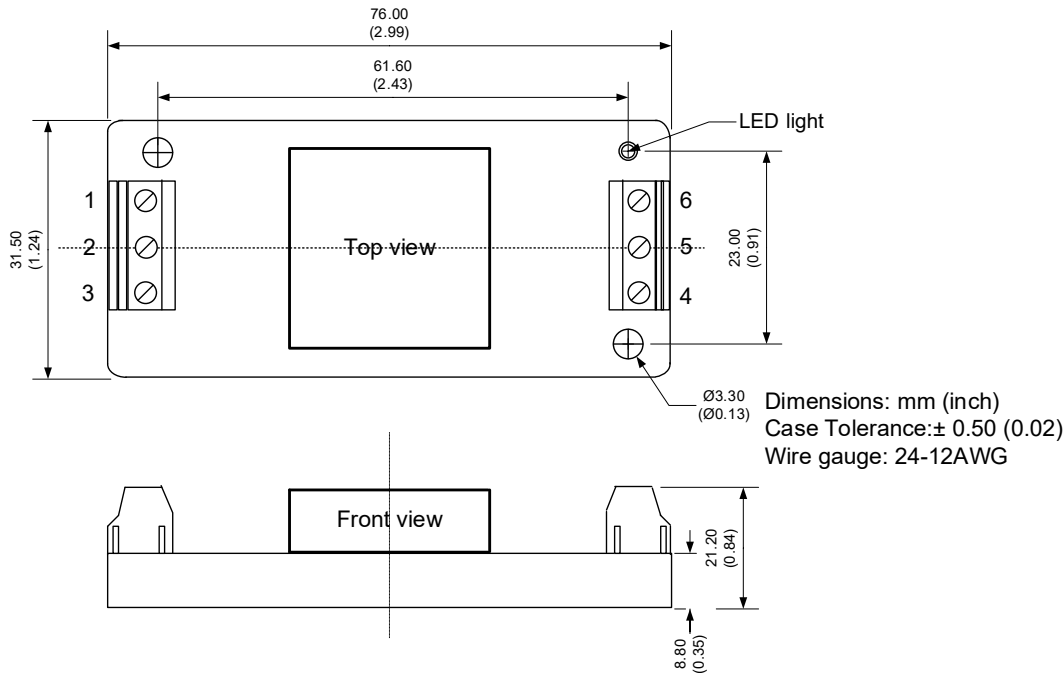

**Pin Out Specifications**

Pin	Single
1	On/Off Control
2	-Vin
3	+Vin
4	+ Vout
5	Trim
6	- Vout

**Dimensions with -STD options**

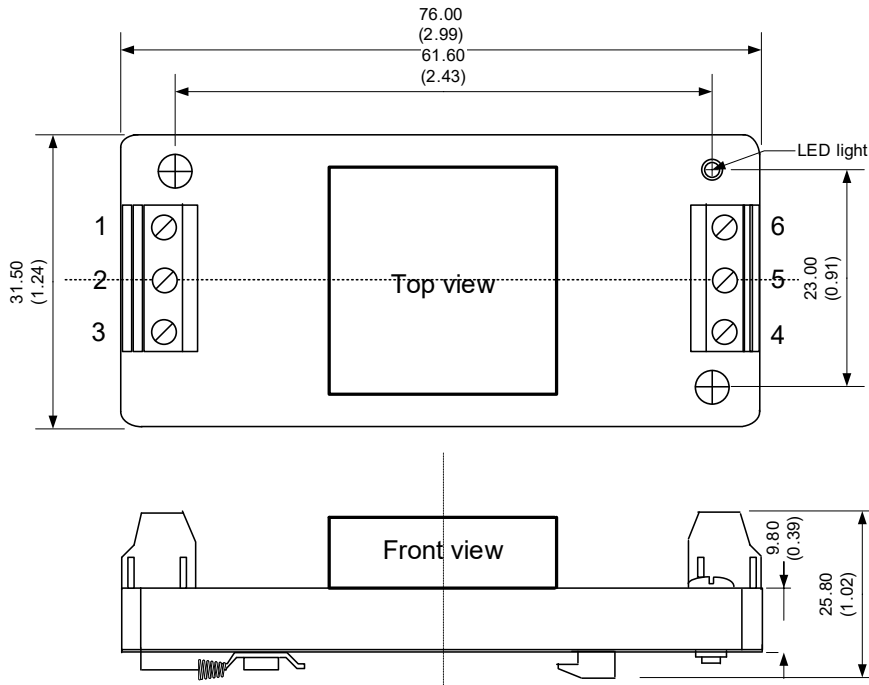

Dimensions: mm (inch)  
Case Tolerance:  $\pm 1.00$  (0.04)  
Wire gauge: 24-12AWG

**Pin Out Specifications**

Pin	Single
1	On/Off Control
2	-Vin
3	+Vin
4	+ Vout
5	Trim
6	- Vout

**Dimensions with heatsink and -ST options**

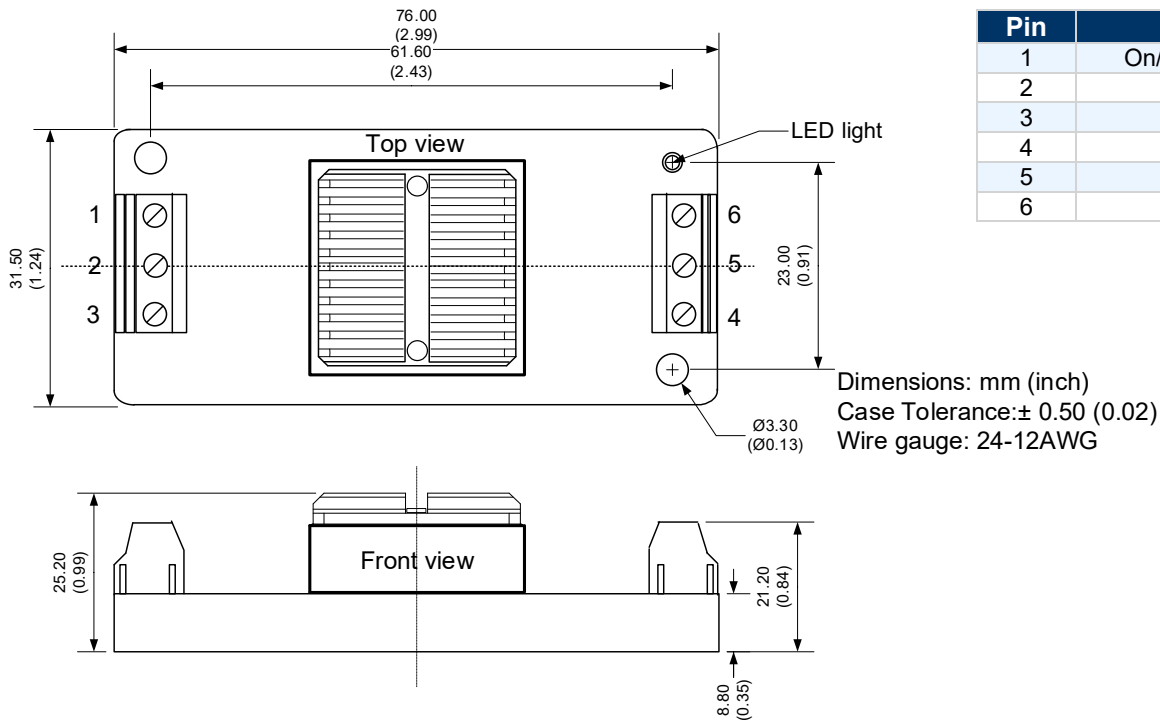

Dimensions: mm (inch)  
Case Tolerance:  $\pm 0.50$  (0.02)  
Wire gauge: 24-12AWG

**Pin Out Specifications**

Pin	Single
1	On/Off Control
2	-Vin
3	+Vin
4	+ Vout
5	Trim
6	- Vout

**Dimensions with heatsink and -STD options**

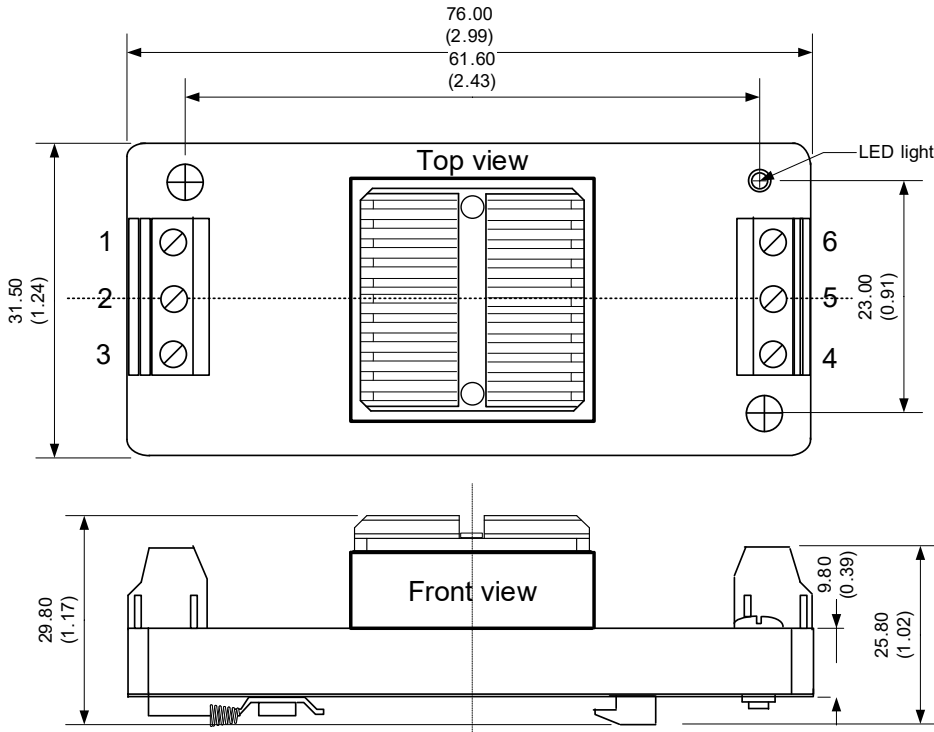

**Pin Out Specifications**

Pin	Single
1	On/Off Control
2	-Vin
3	+Vin
4	+ Vout
5	Trim
6	- Vout

Dimensions: mm (inch)  
 Case Tolerance: ± 0.50 (0.02)  
 Wire gauge: 24-12AWG

**Derating**

**3.3V & 5V single output models**

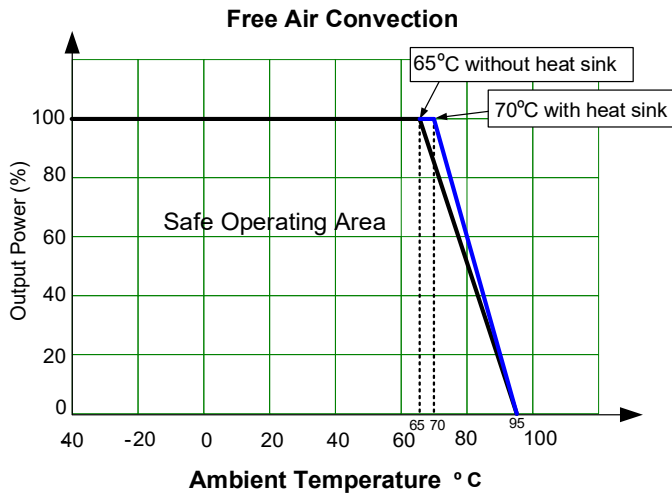

**Other single output models**

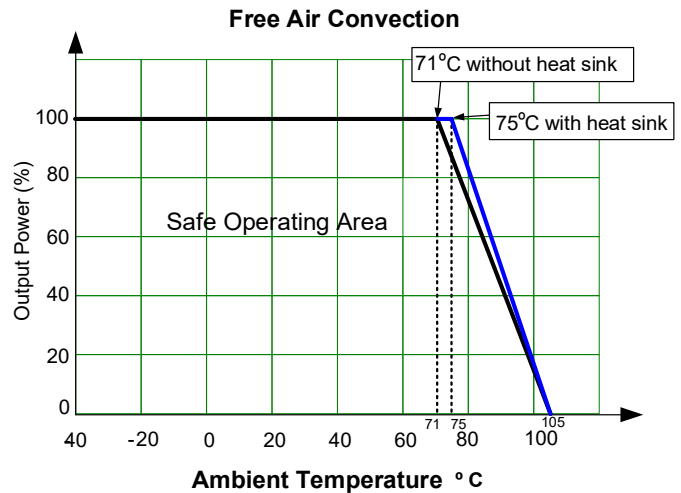

**±5V dual output model**  
Free Air Convection

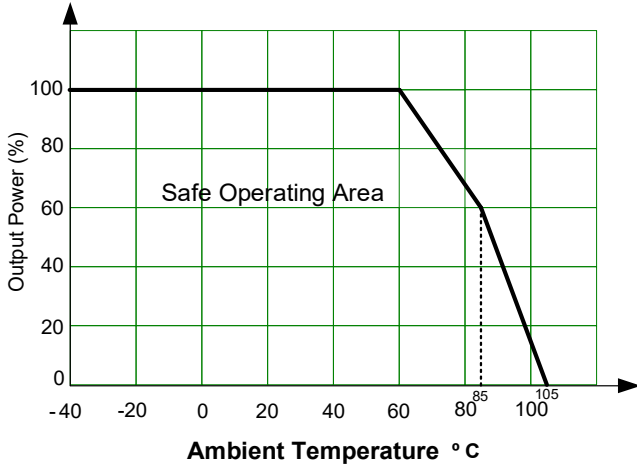

**Other Dual output models**  
Free Air Convection

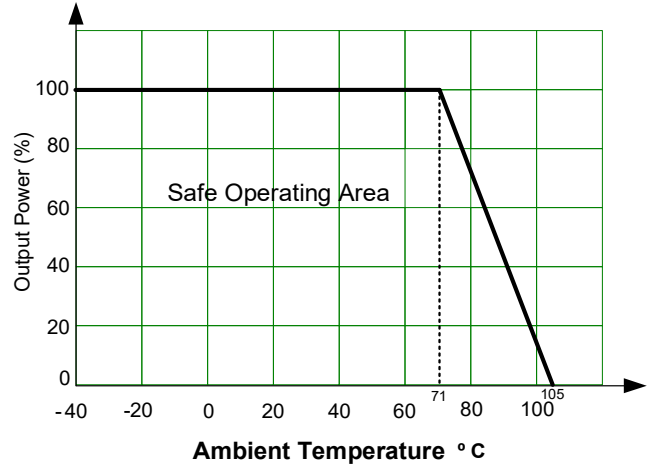

**24V output model**  
Free Air Convection

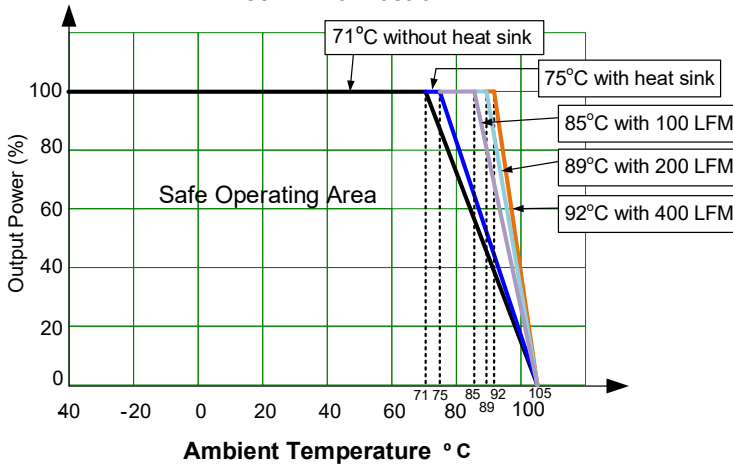

### Typical Application Circuit

#### Single

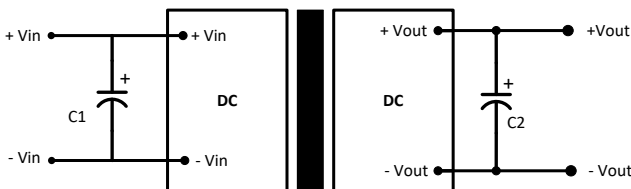

Model	Single 3.3/5/12/15V output	Single 24V output
C1	100µF	
C2	100µF	47µF

#### Dual

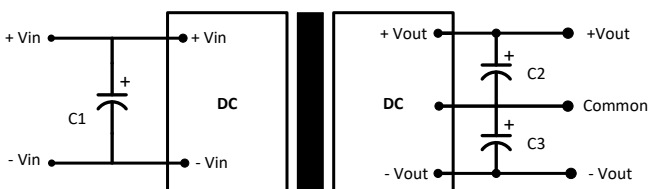

Model	24V input dual output	48V input dual output
C1	100µF	10 - 47µF
C2	10µF	
C3	10µF	

### Recommended EMC Circuit

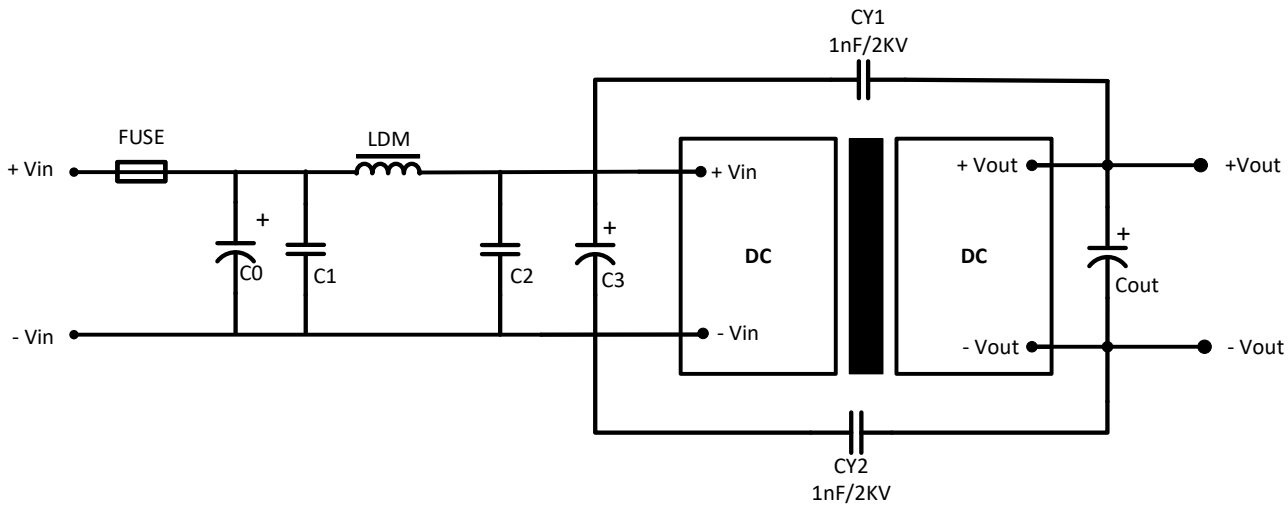

Model	24V input single output	48V input single output
C0, C3	330 $\mu$ F/50V	330 $\mu$ F/100V
C1, C2	4.7 $\mu$ F/50V	4.7 $\mu$ F/100V
LDM	2.2 $\mu$ H/4A	2.2 $\mu$ H/2A
Cout	Refer to typical circuit C2	

Model	24V input dual output	48V input dual output
C0, C3	330 $\mu$ F/50V	330 $\mu$ F/100V
C1, C2	4.7 $\mu$ F/50V	4.7 $\mu$ F/100V
LDM	4.7 $\mu$ H	
Cout	Refer to typical circuit C2	

### Trimming

Output voltage can be externally trimmed by utilizing the methods as shown below

#### Fixed Resistor

#### Variable Potentiometer

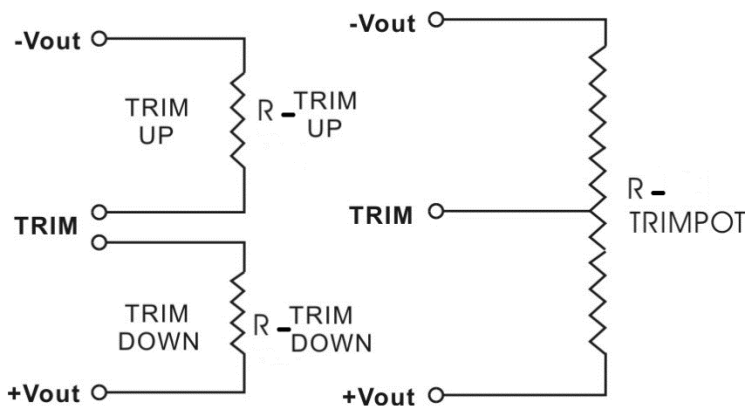

Leave open if not used.



**3.3V Output**

Trim down %	1	2	3	4	5	6	7	8	9	10
Vout (VDC)	3.267	3.234	3.201	3.168	3.135	3.102	3.069	3.036	3.003	2.97
Rt down (KΩ)	149.795	89.213	60.517	43.778	32.811	25.070	19.314	14.866	11.325	8.441
Trim up %	1	2	3	4	5	6	7	8	9	10
Vout (VDC)	3.333	3.366	3.399	3.432	3.465	3.498	3.531	3.564	3.597	3.63
Rt up (KΩ)	891.884	136.200	67.476	41.703	28.202	19.894	14.266	10.202	7.128	4.723

**5V Output**

Trim down %	1	2	3	4	5	6	7	8	9	10
Vout (VDC)	4.95	4.9	4.85	4.8	4.75	4.7	4.65	4.6	4.55	4.5
Rt down (KΩ)	89.996	47.446	29.793	20.131	14.036	9.840	6.775	4.439	2.598	1.111
Trim up %	1	2	3	4	5	6	7	8	9	10
Vout (VDC)	5.05	5.1	5.15	5.2	5.25	5.3	5.35	5.4	5.45	5.5
Rt up (KΩ)	238.676	81.473	46.044	30.398	21.581	15.923	11.985	9.085	6.861	5.101

**12V Output**

Trim down %	1	2	3	4	5	6	7	8	9	10
Vout (VDC)	11.88	11.76	11.64	11.52	11.4	11.28	11.16	11.04	10.92	10.8
Rt down (KΩ)	493.692	299.052	210.127	159.185	126.173	103.042	85.932	72.764	62.316	53.823
Trim up %	1	2	3	4	5	6	7	8	9	10
Vout (VDC)	12.12	12.24	12.36	12.48	12.6	12.72	12.84	12.96	13.08	13.2
Rt up (KΩ)	704.035	156.520	81.479	51.675	35.677	25.695	18.874	13.917	10.152	7.195

**15V Output**

Trim down %	1	2	3	4	5	6	7	8	9	10
Vout (VDC)	14.85	14.7	14.55	14.4	14.25	14.1	13.95	13.8	13.65	13.5
Rt down (KΩ)	632.483	398.237	286.114	220.359	177.137	146.560	123.787	106.169	92.132	80.687
Trim up %	1	2	3	4	5	6	7	8	9	10
Vout (VDC)	15.15	15.3	15.45	15.6	15.75	15.9	16.05	16.2	16.35	16.5
Rt up (KΩ)	1457.699	190.174	94.242	58.954	40.616	29.381	21.791	16.321	12.190	8.961

**24V Output**

Trim down %	1	2	3	4	5	6	7	8	9	10
Vout (VDC)	23.76	23.52	23.28	23.04	22.8	22.56	22.32	22.08	21.84	21.6
Rt down (KΩ)	1284.000	789.923	563.667	433.904	349.754	290.763	247.115	213.514	186.847	165.170
Trim up %	1	2	3	4	5	6	7	8	9	10
Vout (VDC)	24.24	24.48	24.72	24.96	25.2	25.44	25.68	25.92	26.16	26.4
Rt up (KΩ)	814.689	177.714	92.138	58.264	40.107	28.788	21.057	15.440	11.176	7.827

**NOTE:** 1. Datasheets are updated as needed and as such, specifications are subject to change without notice. Once printed or downloaded, datasheets are no longer controlled by Aimtec; refer to [www.aimtec.com](http://www.aimtec.com) for the most current product specifications. 2. Product labels shown, including safety agency certifications on labels, may vary based on the date manufactured. 3. Mechanical drawings and specifications are for reference only. 4. All specifications are measured at an ambient temperature of 25°C, humidity < 75%, nominal input voltage and at rated output load unless otherwise specified. 5. Aimtec may not have conducted destructive testing or chemical analysis on all internal components and chemicals at the time of publishing this document. CAS numbers and other limited information are considered proprietary and may not be available for release. 6. This product is not designed for use in critical life support systems, equipment used in hazardous environments, nuclear control systems or other such applications which necessitate specific safety and regulatory standards other than the ones listed in this datasheet. 7. Warranty is in accordance with Aimtec's standard Terms of Sale available at [www.aimtec.com](http://www.aimtec.com).